

**Model # BPLR2**

**Dimension Sheet**

**ANIMAL PROOF LITTER RECEPTACLE  
 DOUBLE UNIT | 64 (2 X 32) GALLONS**

**Bear Proof Litter Receptacle  
 Specifications and Features:**

- Rust resistant pre-galvanized steel sheet metal construction (12 Ga. Panels, 14 Ga. Doors).
- Stainless Steel hinges and handles.
- Bear resistant latches on both lids and doors, rear door lockable (padlocks not included).
- Lids are self closing and weather proof
- Trash bag support rack has slide-out mechanism for easy removal.
- Bottom tray is angled for easy emptying and cleaning.

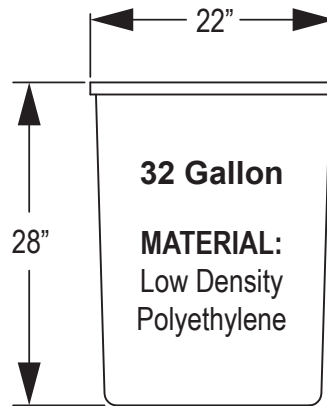

Capacity: 64 Gal.

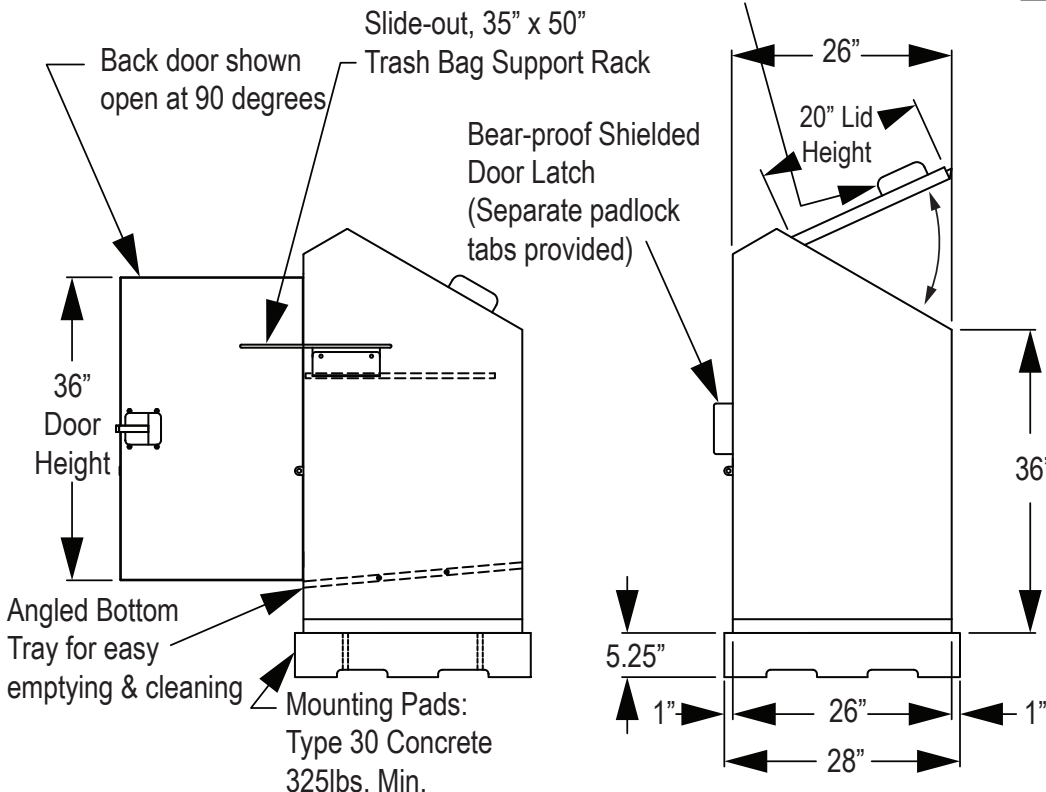
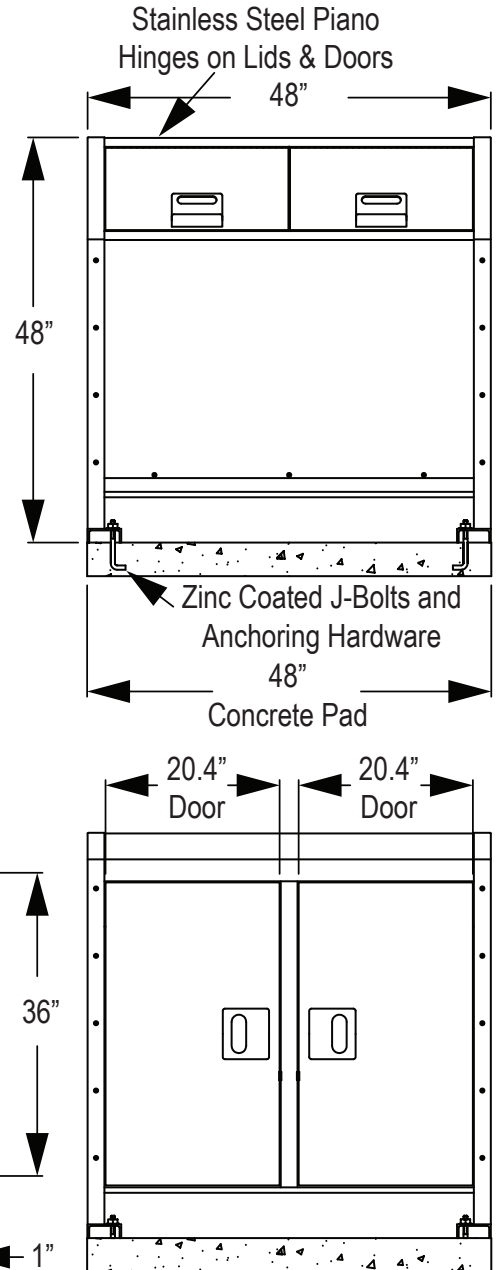

Rear View