

Model # 238-3-T10

Instruction Sheet

## 10' Extra Heavy Duty Shelter Table

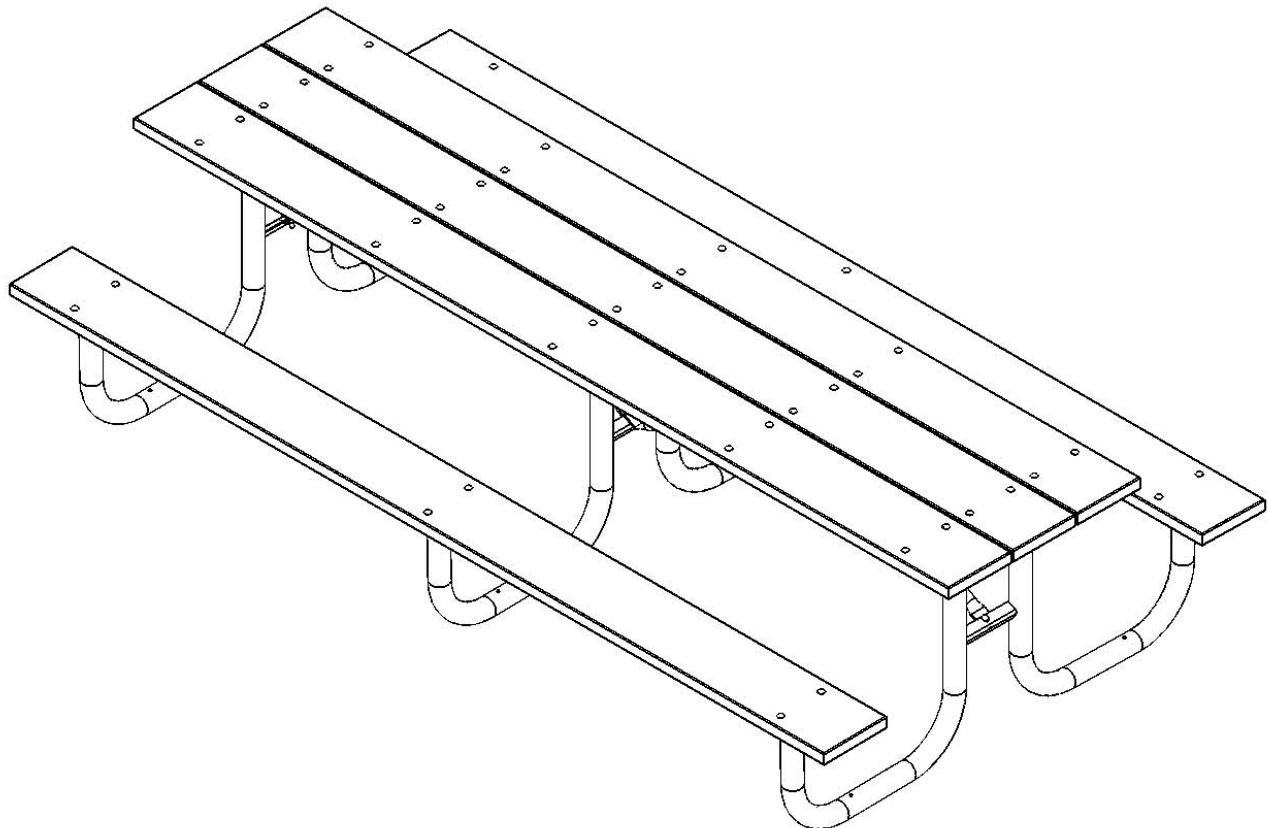

## SAFETY WARNINGS & EQUIPMENT INSPECTION

---

- OWNERS AND INSTALLERS PLEASE NOTE THESE SAFETY WARNINGS AND MAKE USE OF THIS CHECKLIST ON A REGULAR BASIS.
- FOLLOW INSTALLATION INSTRUCTIONS WHEN ERECTING EQUIPMENT.
- GROUND SURFACES AROUND EQUIPMENT SHOULD BE RESTORED AS NEEDED. CONCRETE FOOTINGS SHOULD NEVER BE EXPOSED. SURFACE DEPTH SHOULD COMPLY WITH ASTM AND CPSC SPECIFICATIONS.
- CHECK FOR AND REPAIR DAMAGE CAUSED BY WEAR OR VANDALISM, A MAJOR FACTOR IN INJURY CAUSING SITUATIONS.
- ALL PROTRUDING BOLTS SHOULD BE COVERED OR CUT OFF AND FINISHED SMOOTH. SHARP EDGES ON PIPES SHOULD BE CAPPED OR REMOVED. CHECK FOR BENT, BROKEN, OR SEVERELY WORN PIPE, AND REPLACE.
- ALL EQUIPMENT SHOULD BE FREE OF RUST AND REPAINTED WHENEVER NECESSARY TO DETER RUSTING.
- WE PROVIDE OUR CUSTOMERS WITH LAYOUT SHEETS AND INSTALLATION INSTRUCTIONS. PLEASE KEEP ON FILE THE SPECIFICATIONS SHEET THAT CONTAINS THE LISTING OF EVERY PART USED.
- NEVER ADD COMPONENTS NOT INTENDED FOR USE WITH THIS PRODUCT.
- REGULAR MAINTENANCE IS NECESSARY IN THIS AND ALL PARK AND RECREATIONAL EQUIPMENT TO INSURE THE SAFETY OF THE USER.
- NOTE: PROPER MAINTENANCE OF EQUIPMENT REQUIRES REGULAR TIGHTENING OF ALL BOLTS, NUTS, AND SETSCREWS.
- NOTE: REGULAR CHECKING OF ALL PARTS, CASTINGS, ETC. SHOULD BE MADE. IF A PART IS BROKEN OR WORN, IT SHOULD BE REPLACED IMMEDIATELY.
- CHECK TO BE SURE ALL FITTINGS ARE TIGHT AND THAT BARS AND PIPES DO NOT MOVE.
- REPLACE ALL WORN S-HOOKS. S-HOOKS MUST BE COMPLETELY CLOSED. FAILURE TO CLOSE S-HOOKS CAN RESULT IN SERIOUS INJURY TO THE USER. NEVER REUSE S-HOOKS.
- TEST FOR FREE MOVEMENT OF SWING HANGER AND OTHER MOVING ATTACHED PARTS.
- CHECK FOR WORN CHAINS AND REPLACE THEM.
- A SOFT RESILIENT SURFACE SHOULD BE PLACED UNDER ALL SWINGS EXTENDING AT LEAST TWICE THE HEIGHT OF THE TOP RAIL BOTH FRONT AND BACK.

BEFORE ASSEMBLY, PLEASE MAKE SURE ALL FASTENERS ARE INCLUDED.

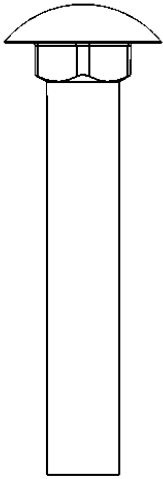

3/8" x 2-1/4" Carriage Bolt

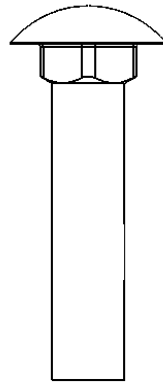

3/8" x 1-3/4" Carriage Bolt

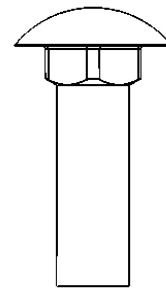

3/8" x 1-1/4" Carriage Bolt

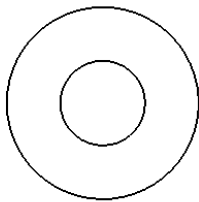

3/8" Flat Washer

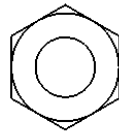

3/8" Hex Nut

ALSO NEEDED FOR THIS ASSEMBLY WILL BE THE FOLLOWING MATERIALS:

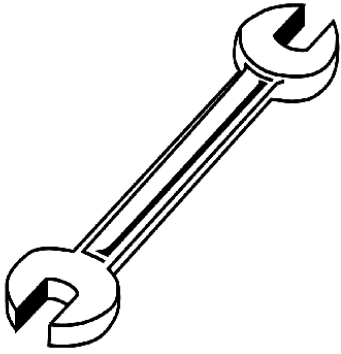

9/16" Wrench

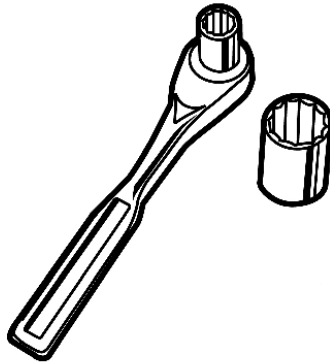

9/16" Socket Wrench

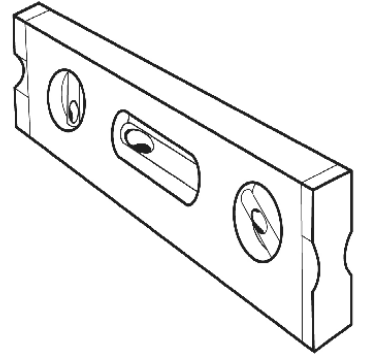

Level

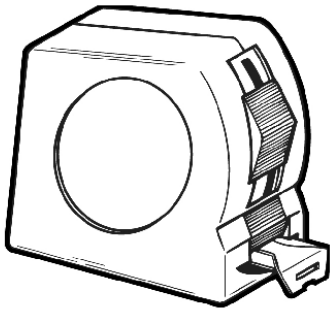

Tape Measure

## PRODUCT SPECIFICATIONS

### 238-3-PT10, T10, U10 EXTRA HEAVY DUTY WOOD SHELTER TABLE

Top & Seats: Pressure Treated : 2" x 10" No. 1 Southern Yellow Pine pressure treated lumber.  
Redwood Stain: 2" x 10" No. 1 Southern Yellow Pine with a redwood stain wood preservative.  
Untreated: 2" x 10" No. 1 Southern Yellow Pine

Frame: 2-3/8" O.D. x 12 gauge pre-galvanized structural steel tubing. Cross braces 1" O.D. x 16 gauge pre-galvanized structural steel tubing. Brace attachment points are 1-1/2"x1-1/2"x3/16" steel angle. All tabletop and seat mounting brackets shall be precision punched and fabricated from 2" x 2" x 7 gauge formed angle. Legs are bent over a mandrel through the bend radius producing a wrinkle free bend. Holes are predrilled in legs for optional surface mounting. All electrically MIG welded.

Frame Coating: Electrostatic powder coated application oven cured or hot dipped galvanized.

Hardware: Hardware shall be hot-dipped galvanized.

Dimensions: 10' portable picnic table walk-through design. Top is 28-1/4" wide x 120" long and is 30" high. Seats are 9-1/4" wide x 120" long and 18" high. Outside to outside dimension is 65" x 120".

## COMPONENTS

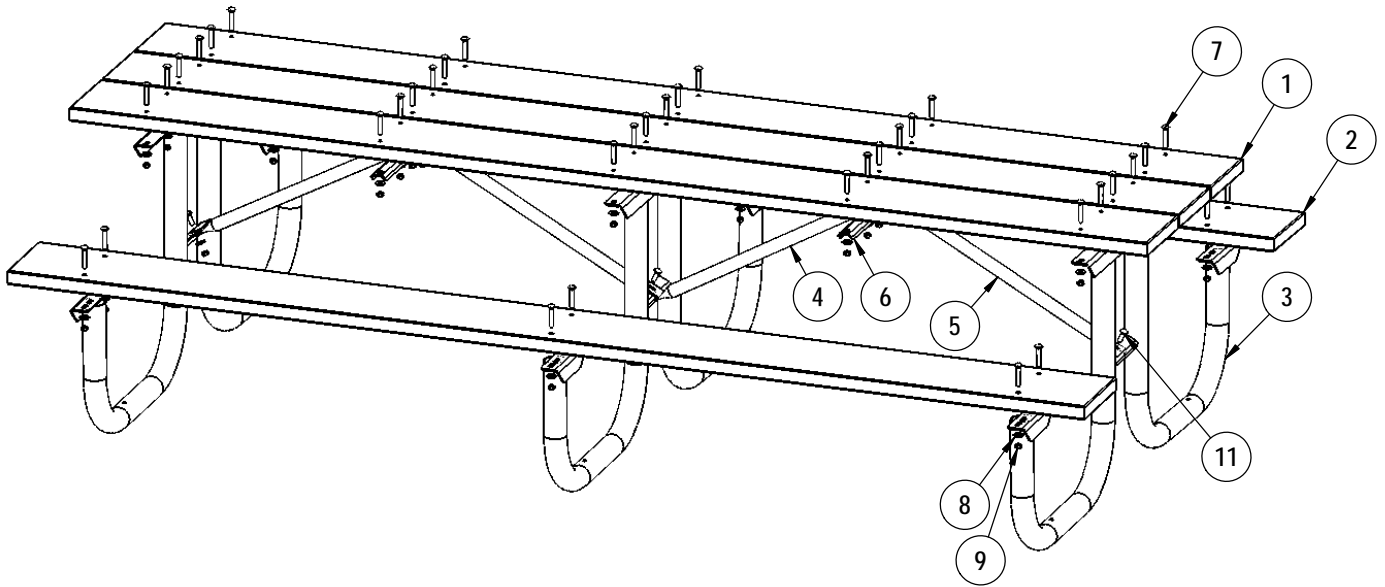

ITEM NO.	PartNo	DESCRIPTION	Qty.
1	PT120-2x10-T, RST120-2x10-T, or U120-2x10-T	2 x 10 Pressure Treated Table Plank (10'), 2 x 10 Redwood Stained Table Plank (10'), or 2 x 10 Untreated Table Plank (10')	3
2	XXX120-2x10-S	2 x 10 Pressure Treated/Untreated/Redwood Stained Seat Plank (10')	2
3	P-W238 or G- W238	238 wood frame	3
4	01-04-0236	31" Wood Table Brace	1
5	01-04-0165	6' wood table brace (30-1/4")	3
6	01-04-0027	center c channel	2
7	33-06-0016	3/8" x 2-1/4" Carriage Bolt (Zinc)	42
8	33-02-0002	3/8" Zinc Plated Washer	47
9	33-01-0002	3/8" Hex Nut (Zinc)	47
10	33-06-0005	3/8" x 1 3/4" Carriage Bolt (Zinc)	2
11	33-06-0032	3/8" x 1-1/4" Carriage Bolt (Zinc)	3

# STEP 1

Attach the 10' Top Planks to the 238 Frames using the specified hardware.

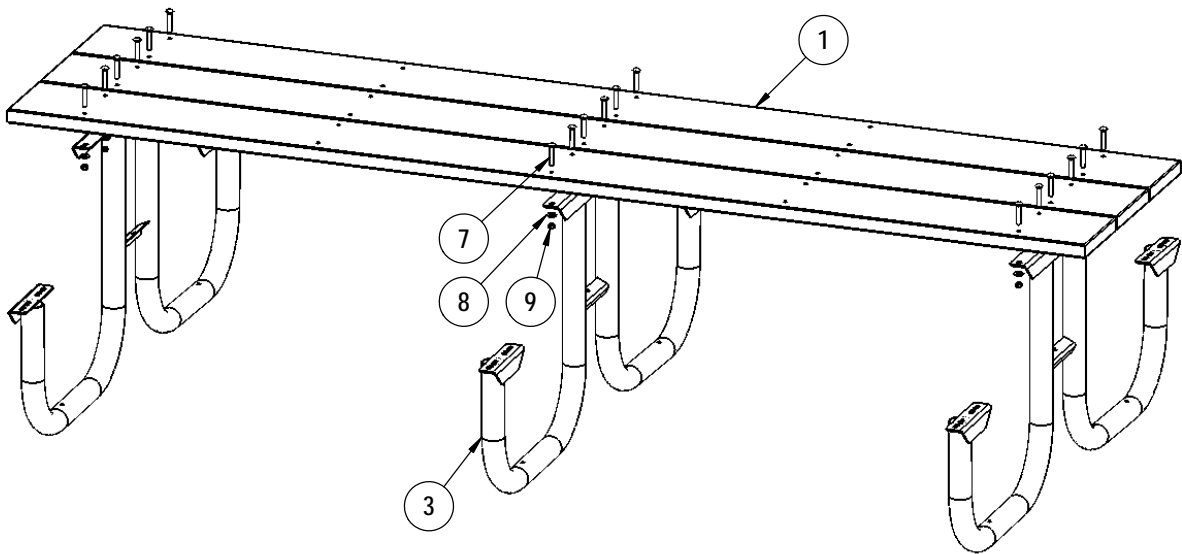

## STEP 2

Attach the center channels to the 2 x 10 Top Planks as shown using the specified hardware.  
**NOTE:** A 3/8"-16 x 1-3/4" Carriage Bolt is placed in the center hole of the Center C Channels.  
Head of Carriage Bolt shall be between top of channels and bottom of 2 x 10 planks.

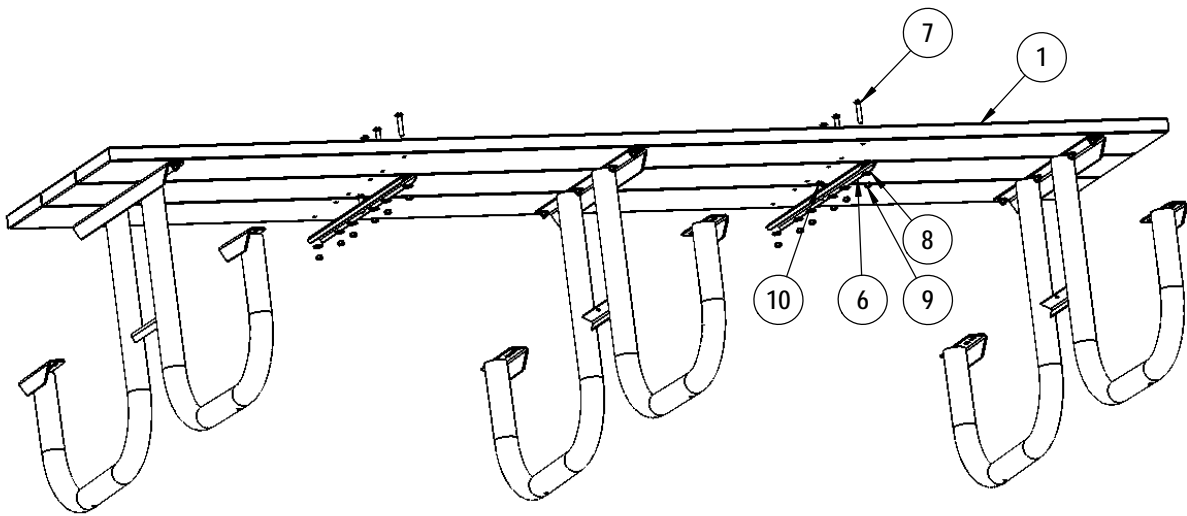



### STEP 3

Attach the 31" Wood Table Brace and the 30-1/4" Wood Table Braces to the Center C Channels and the 238 Frames using the specified hardware.

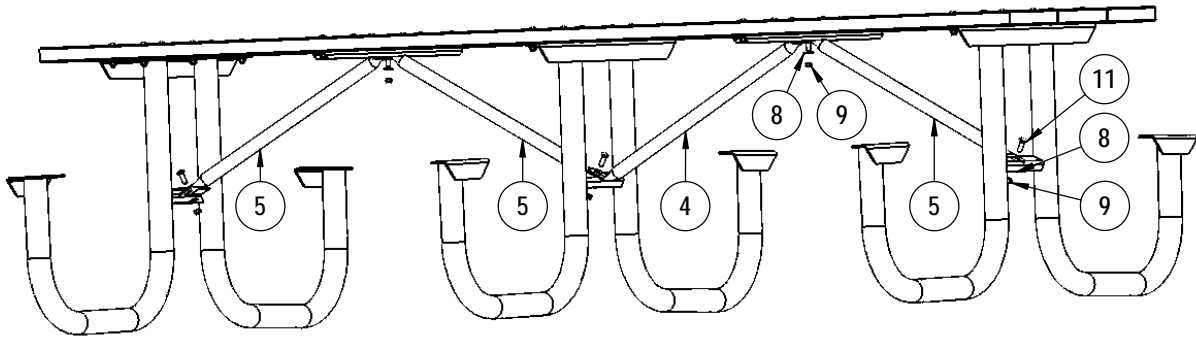

## STEP 4

Attach the 10' Seat Planks to the 238 Frames using the specified hardware.

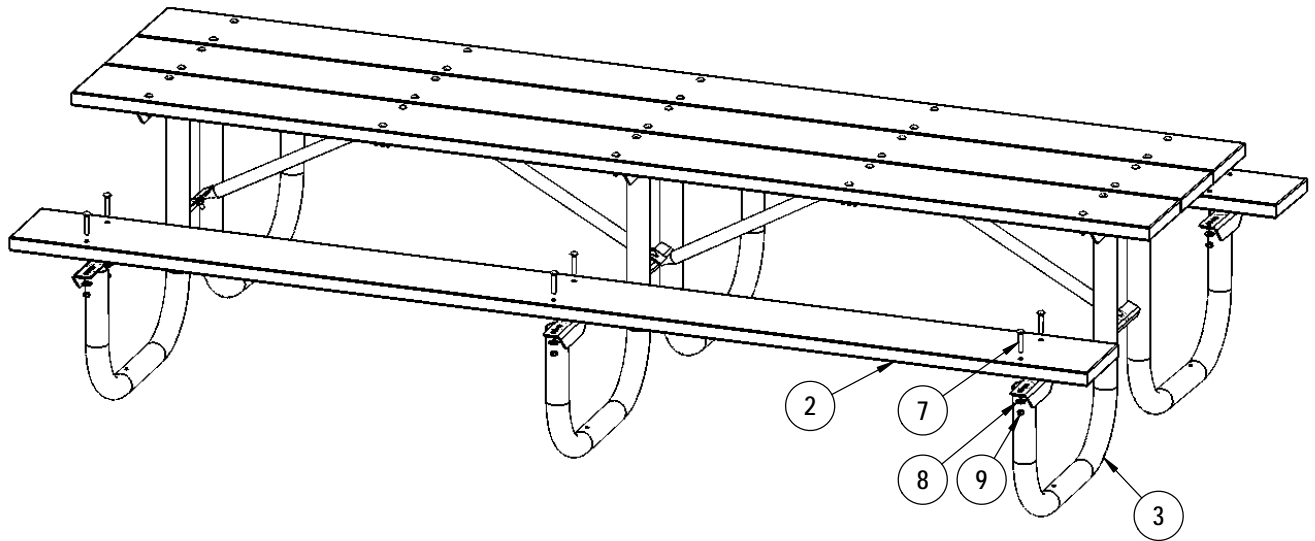

# OVERALL DIMENSIONS

