

Model # 940P-EV8

Instruction Sheet

E-SERIES 8' BENCH WITH BACK, 2" X 10" PLANKS, PORTABLE

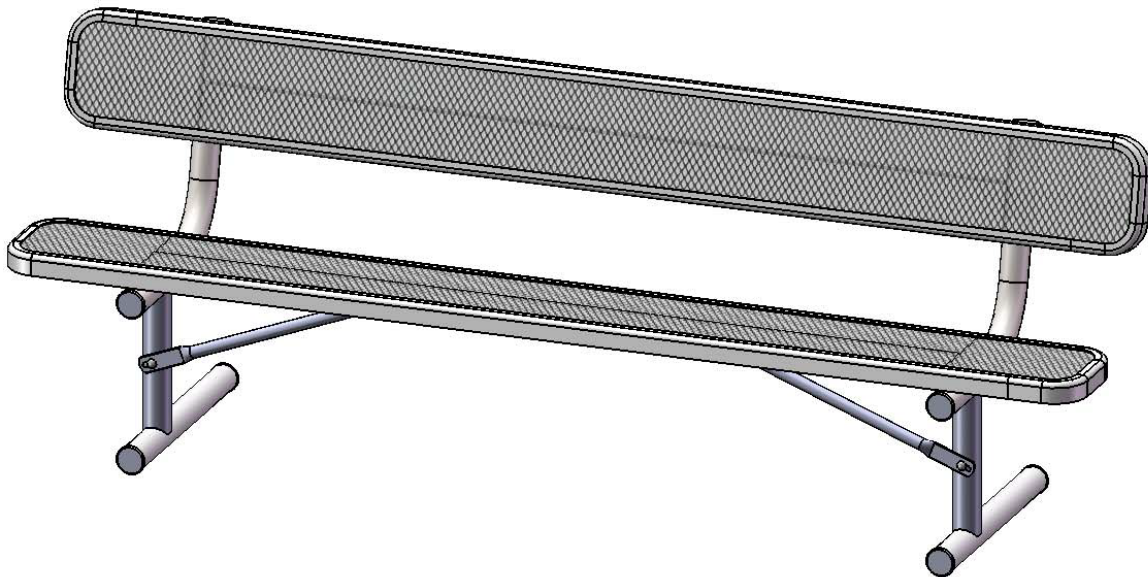

SAFETY WARNINGS & EQUIPMENT INSPECTION

- OWNERS AND INSTALLERS PLEASE NOTE THESE SAFETY WARNINGS AND MAKE USE OF THIS CHECKLIST ON A REGULAR BASIS.
- FOLLOW INSTALLATION INSTRUCTIONS WHEN ERECTING EQUIPMENT.
- GROUND SURFACES AROUND EQUIPMENT SHOULD BE RESTORED AS NEEDED. CONCRETE FOOTINGS SHOULD NEVER BE EXPOSED. SURFACE DEPTH SHOULD COMPLY WITH ASTM AND CPSC SPECIFICATIONS.
- CHECK FOR AND REPAIR DAMAGE CAUSED BY WEAR OR VANDALISM, A MAJOR FACTOR IN INJURY CAUSING SITUATIONS.
- ALL PROTRUDING BOLTS SHOULD BE COVERED OR CUT OFF AND FINISHED SMOOTH. SHARP EDGES ON PIPES SHOULD BE CAPPED OR REMOVED. CHECK FOR BENT, BROKEN, OR SEVERELY WORN PIPE, AND REPLACE.
- ALL EQUIPMENT SHOULD BE FREE OF RUST AND REPAINTED WHENEVER NECESSARY TO DETER RUSTING.
- WE PROVIDE OUR CUSTOMERS WITH LAYOUT SHEETS AND INSTALLATION INSTRUCTIONS. PLEASE KEEP ON FILE THE SPECIFICATIONS SHEET THAT CONTAINS THE LISTING OF EVERY PART USED.
- NEVER ADD COMPONENTS NOT INTENDED FOR USE WITH THIS PRODUCT.
- REGULAR MAINTENANCE IS NECESSARY IN THIS AND ALL PARK AND RECREATIONAL EQUIPMENT TO INSURE THE SAFETY OF THE USER.
- NOTE: PROPER MAINTENANCE OF EQUIPMENT REQUIRES REGULAR TIGHTENING OF ALL BOLTS, NUTS, AND SETSCREWS.
- NOTE: REGULAR CHECKING OF ALL PARTS, CASTINGS, ETC. SHOULD BE MADE. IF A PART IS BROKEN OR WORN, IT SHOULD BE REPLACED IMMEDIATELY.
- CHECK TO BE SURE ALL FITTINGS ARE TIGHT AND THAT BARS AND PIPES DO NOT MOVE.
- REPLACE ALL WORN S-HOOKS. S-HOOKS MUST BE COMPLETELY CLOSED. FAILURE TO CLOSE S-HOOKS CAN RESULT IN SERIOUS INJURY TO THE USER. NEVER REUSE S-HOOKS.
- TEST FOR FREE MOVEMENT OF SWING HANGER AND OTHER MOVING ATTACHED PARTS.
- CHECK FOR WORN CHAINS AND REPLACE THEM.
- A SOFT RESILIENT SURFACE SHOULD BE PLACED UNDER ALL SWINGS EXTENDING AT LEAST TWICE THE HEIGHT OF THE TOP RAIL BOTH FRONT AND BACK.

BEFORE ASSEMBLY, PLEASE MAKE SURE ALL FASTENERS ARE INCLUDED.

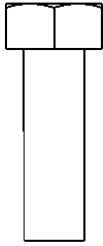

5/16" x 1" Machine Bolt

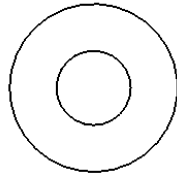

5/16" Flat Washer

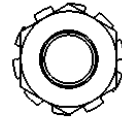

5/16" Kep Nut

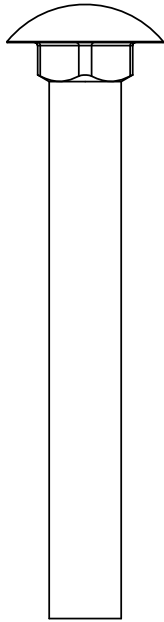

3/8" x 3" Carriage Bolt

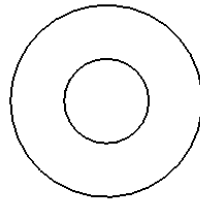

3/8" Flat Washer

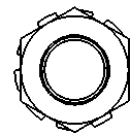

3/8" Kep Nut

ALSO NEEDED FOR THIS ASSEMBLY WILL BE THE FOLLOWING MATERIALS:

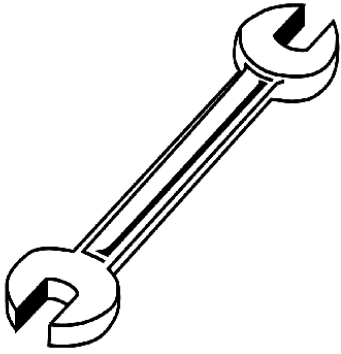

1/2" & 9/16" Wrench

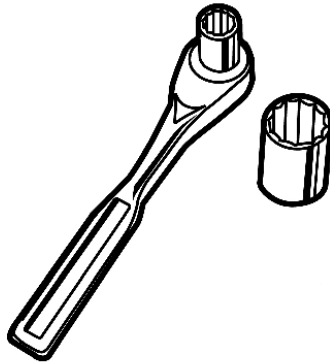

1/2" & 9/16" Socket Wrench

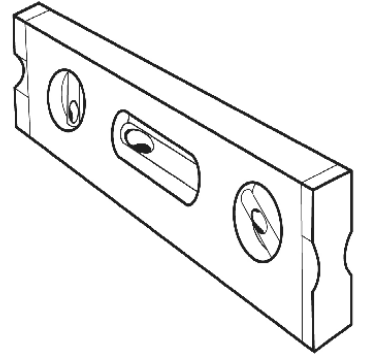

Level

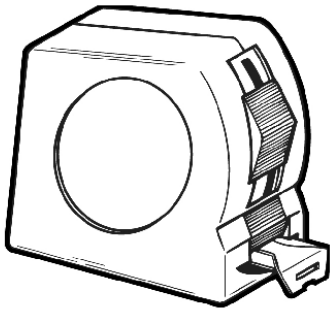

Tape Measure

PRODUCT SPECIFICATIONS

940P-EV8 PORTABLE BENCH WITH BACK

Seat & Back: 11 gauge die formed angle frame 1"x1-7/8" with 3" radius corners. 3/4" #9 steel expanded metal. 10 gauge x 1-1/2" flat bar center support and mounting bracket understructure. Electrically MIG welded.

Coating: Oven fused functionalized polyethylene copolymer-based thermoplastic. Fluidized bed coating application with superior mechanical performance, impact resistance and UV-stability.

Frame: 2-3/8" O.D. x 12 gauge pre-galvanized structural steel tubing. Seat/back support is bent over a mandrel through the bend radius producing a wrinkle free bend. Tube ends are pre-galvanized steel capped. Seat mounting points are 7 gauge x 1-1/2" die stamped steel flat bar. Cross braces are 1" O.D. x 16 gauge pre-galvanized structural steel tubing. All electrically MIG welded.

Frame Coating: Electrostatic powder coated application oven cured.

Hardware: All stainless steel hardware fasteners.

Dimensions: 8' bench portable with back. Seats and back are 10" wide x 96" long. Seat height is 18 1/4", seat back height is 34 1/4". Total depth of seat with back is 21 5/16".

COMPONENTS

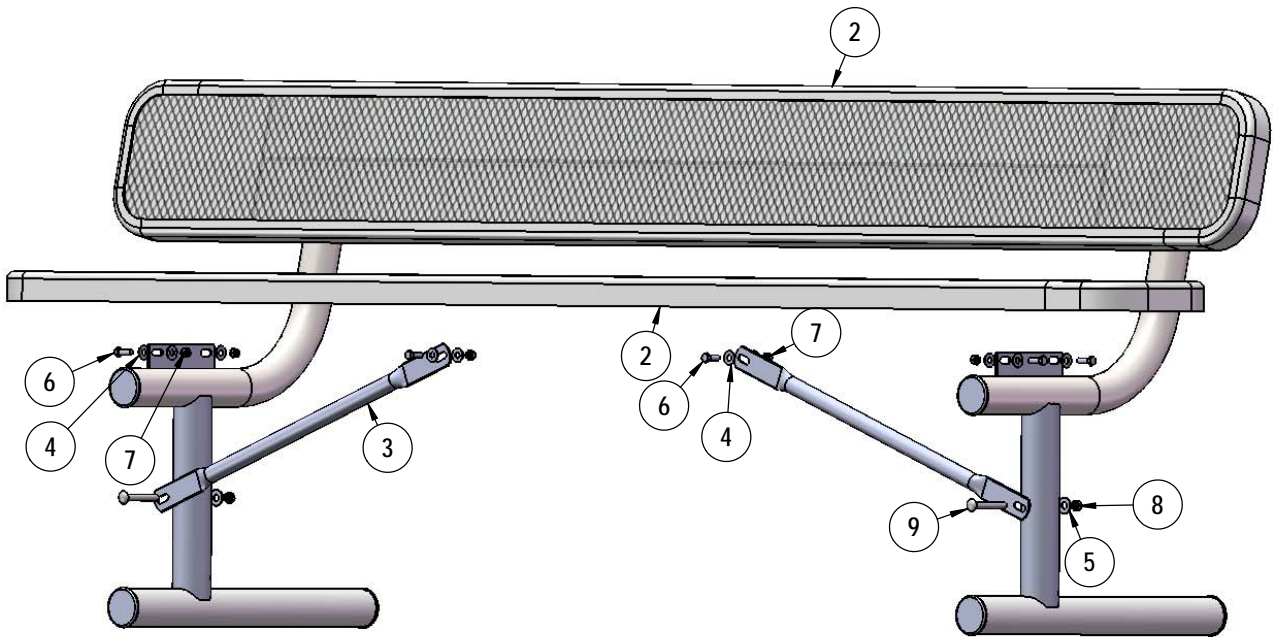

ITEM NO.	PartNo	DESCRIPTION	QTY
1	P-V940P	940P Vinyl Leg	2
2	T-EV96-S	8' x 10" expanded seat	2
3	P-01-04-0129	26 3/4" Brace	2
4	33-02-0007	5/16" SS Washer	20
5	33-02-0008	3/8" Flat Washer (SS)	2
6	33-05-0029	5/16" x 1" Machine Bolt (SS)	10
7	33-03-0012	5/16" Keps Nut (SS)	10
8	33-03-0013	3/8" Keps Nut (SS)	2
9	33-06-0058	3/8" x 3" Carriage Bolt (SS)	2

STEP 1

Attach the 8' Expanded Seat to the 940 legs using specified hardware.

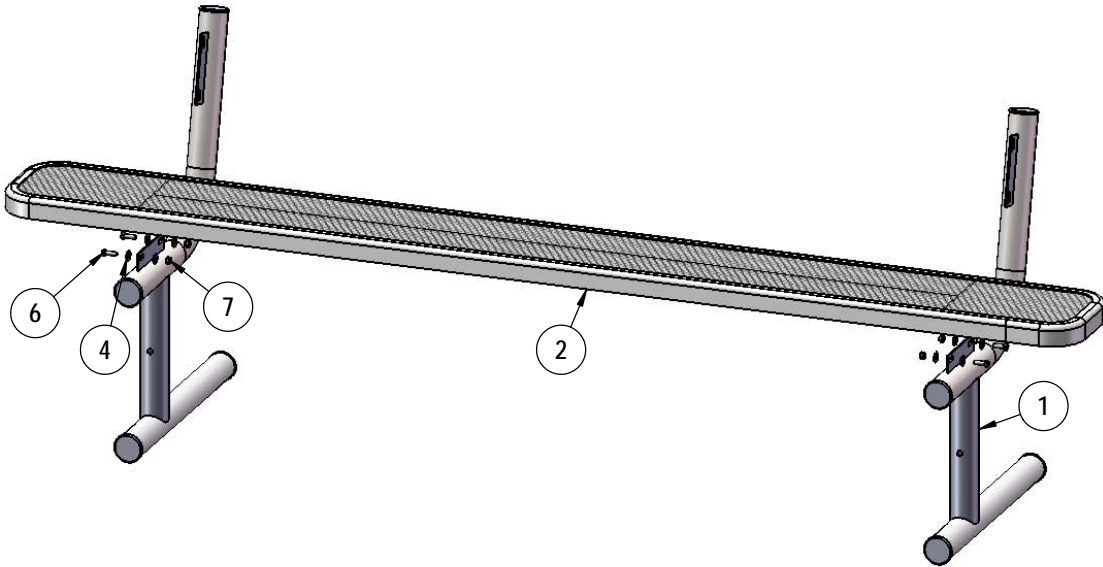

STEP 2

Repeat Step 1 for the back.

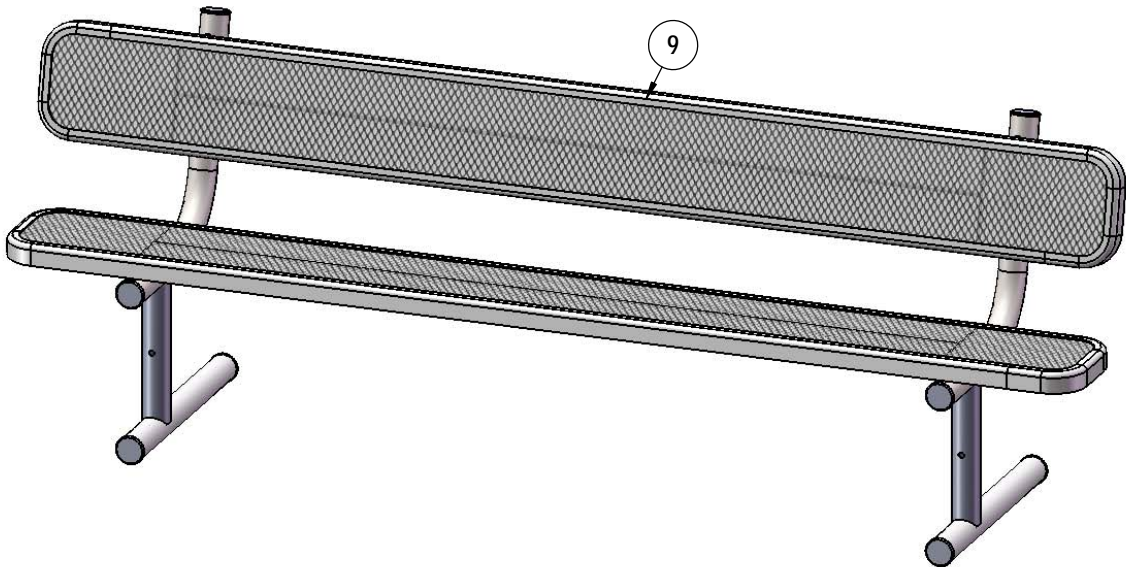

STEP 3

Attach the 26 3/4" Braces to the 940 seats and legs as shown using specified hardware.

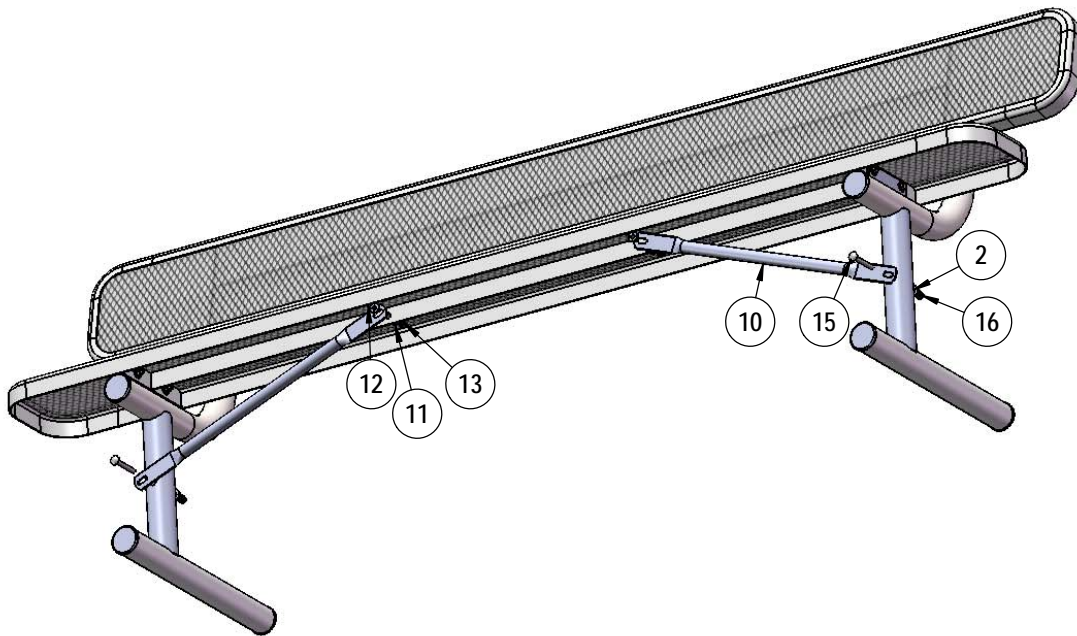

OVERALL DIMENSIONS

