

Model # CA6WB-P

Instructions Sheet

CAMBRIDGE RECYCLED PLASTIC MEMORIAL PARK BENCH

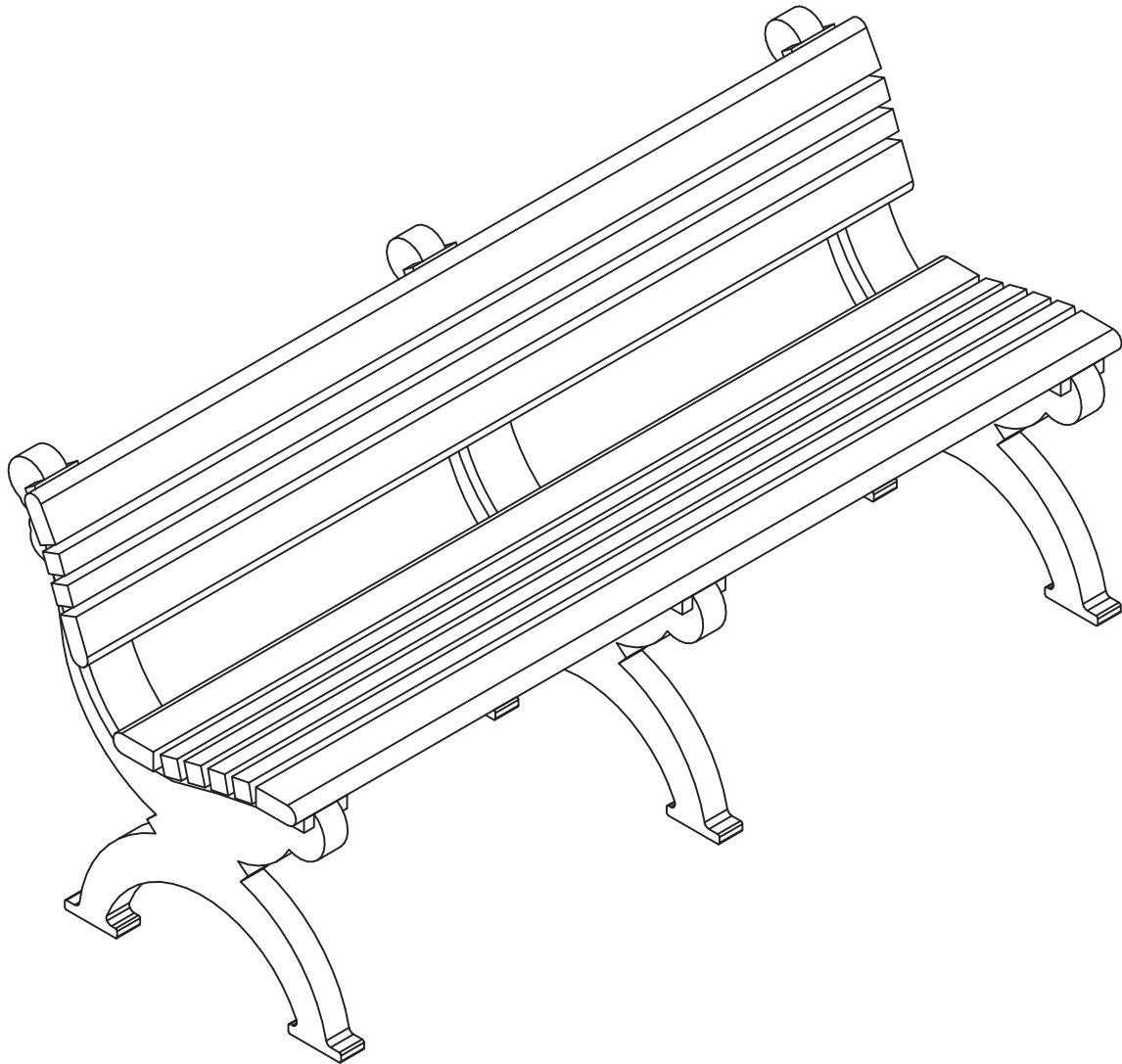

BEFORE ASSEMBLY, PLEASE MAKE SURE ALL COMPONENTS ARE INCLUDED.

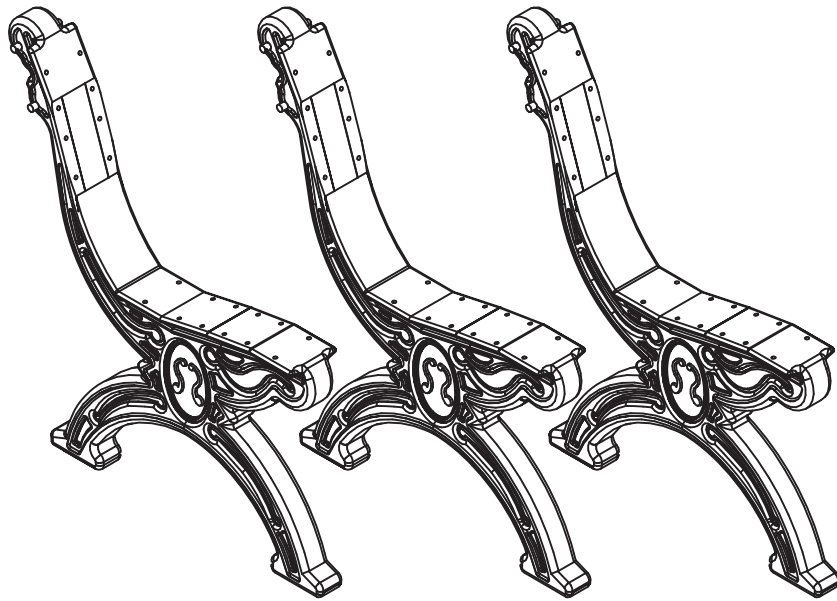

D - BENCH END
(3) - THREE BENCH ENDS

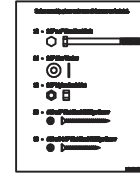

FP - FASTENER PACK
(1) - ONE FASTENER PACK

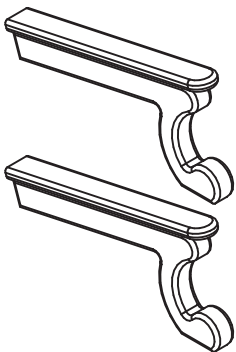

E - ARM
(2) - TWO ARMS

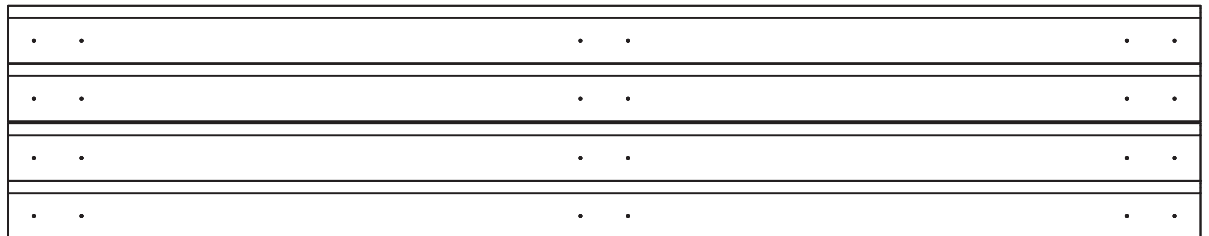

A - BULL NOSE BENCH BOARD
(4) - FOUR BULL NOSE BENCH BOARDS

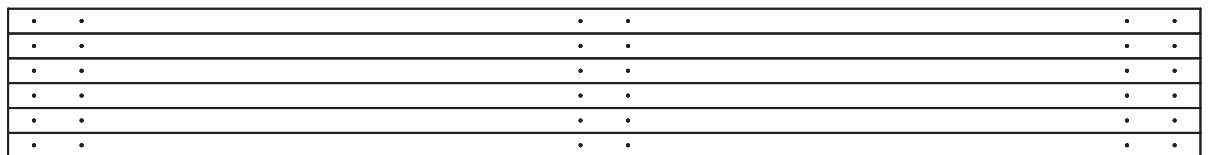

B - BENCH BOARD
(6) - SIX BENCH BOARDS

BEFORE ASSEMBLY, PLEASE MAKE SURE ALL FASTENERS ARE INCLUDED.

60 - #12 X 1-1/2" PAN HEAD PHILLIPS SCREW



ALSO NEEDED FOR THIS ASSEMBLY WILL BE THE FOLLOWING MATERIALS:

1 - 3" PHILLIPS DRIVE BIT

FIG #1:

IN ORDER TO MAKE THE ASSEMBLY OF THIS CAMBRIDGE BENCH EASIER, WHILE GOING THROUGH THE ASSEMBLY PROCESS, THE BOARD POSITIONS ARE NUMBERED AND WILL BE REFERENCED IN LATER STEPS.

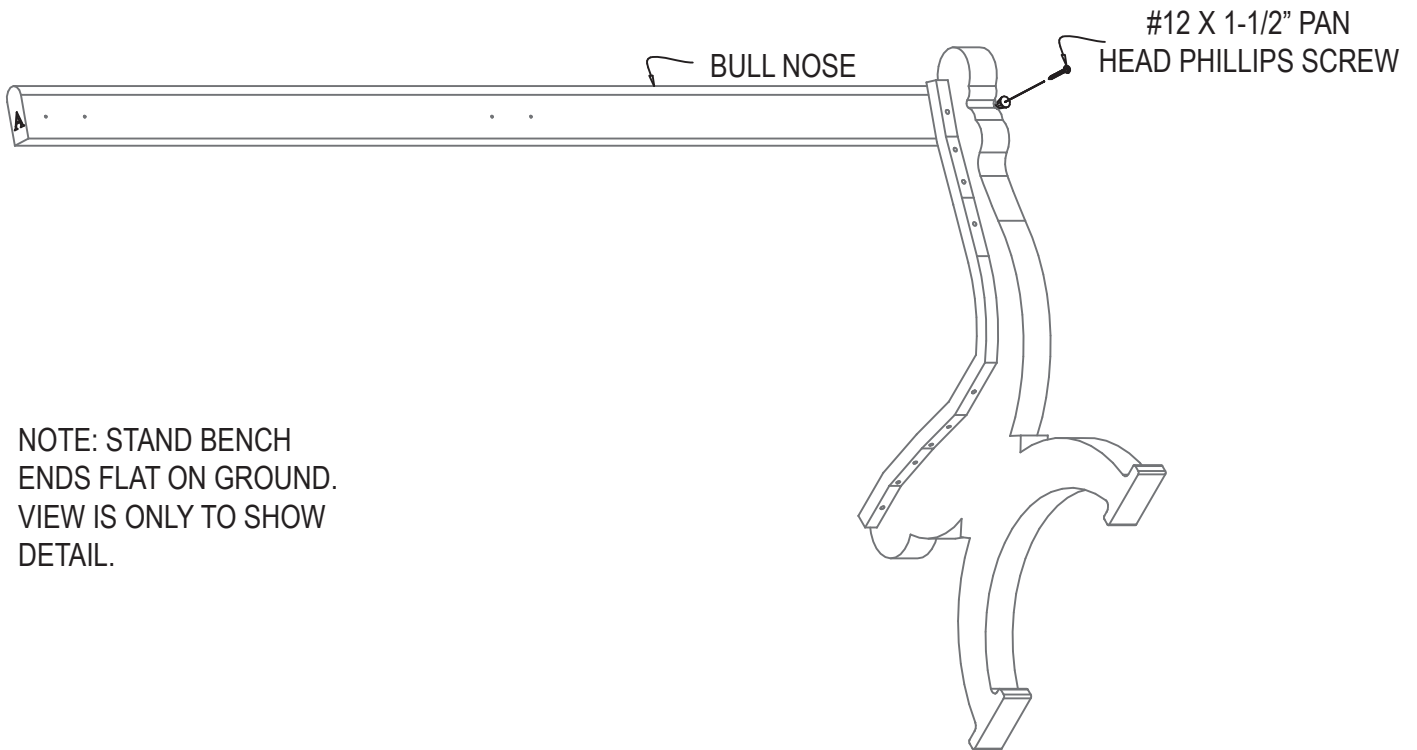
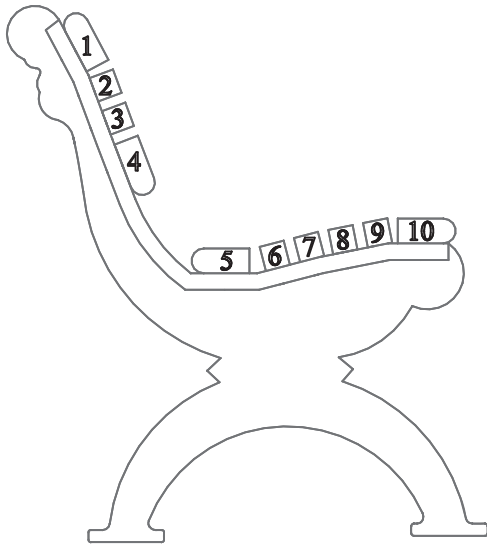

NOTE: STAND BENCH ENDS FLAT ON GROUND. VIEW IS ONLY TO SHOW DETAIL.

STEP #1: STAND (1) ONE BENCH END UPRIGHT AND PLACE (1) ONE BULL NOSE BENCH BOARD (A) ON POSITION 1, BEING SURE TO ALIGN THE PILOT HOLES TO THE PRE-DRILLED HOLES IN THE BENCH END. AFTER THE HOLES ARE PROPERLY ALIGNED, FASTEN WITH (1) ONE #12 X 1-1/2" PAN HEAD PHILLIPS SCREW IN THE PRE-DRILLED HOLE ON THE RIGHT SIDE OF THE BENCH END. NOTE: DO NOT TIGHTEN SCREW COMPLETELY. THIS WILL BE DONE IN A LATER STEP.

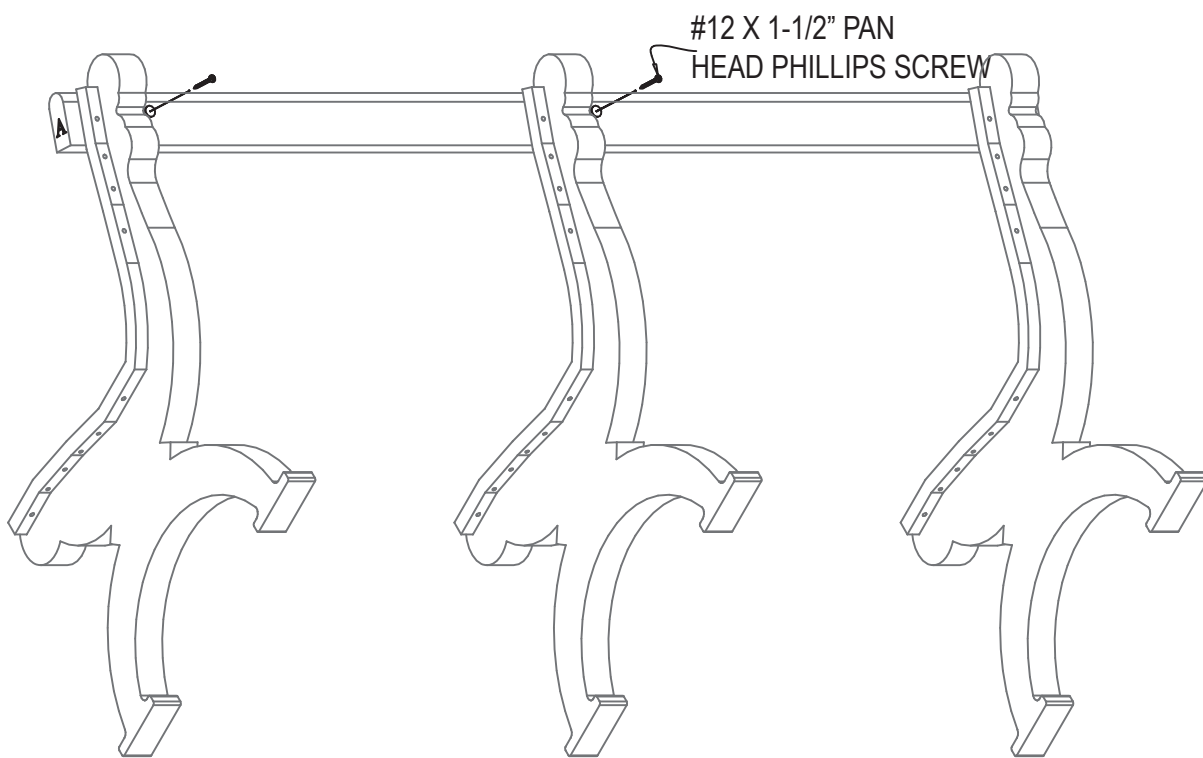

STEP #2: STAND THE OTHER (2) TWO BENCH ENDS UPRIGHT, ONE AT A TIME, AND PLACE THE BULL NOSE BENCH BOARD (A) ALREADY ATTACHED TO THE FIRST BENCH END, ON POSITION 1, BEING SURE TO ALIGN THE PILOT HOLES WITH THE PRE-DRILLED HOLES IN THE BENCH END. AFTER THE HOLES ARE PROPERLY ALIGNED, FASTEN WITH (1) ONE #12 X 1-1/2" PAN HEAD PHILLIPS SCREW IN THE PRE-DRILLED HOLE ON THE RIGHT SIDE OF THE BENCH END.

NOTE: DO NOT TIGHTEN SCREWS COMPLETELY. THIS WILL BE DONE IN A LATER STEP.

STEP #3:

ALIGN THE PILOT HOLES ON THE BULL NOSE BENCH BOARD (A) TO THE PRE-DRILLED HOLES ON THE LEFT SIDE OF THE BENCH ENDS. AFTER THE HOLES ARE PROPERLY ALIGNED, FASTEN WITH (1) ONE #12 X 1-1/2" PAN HEAD PHILLIPS SCREW PER BENCH END.

NOTE: BE SURE TO TIGHTEN SCREWS COMPLETELY AFTER THIS STEP.

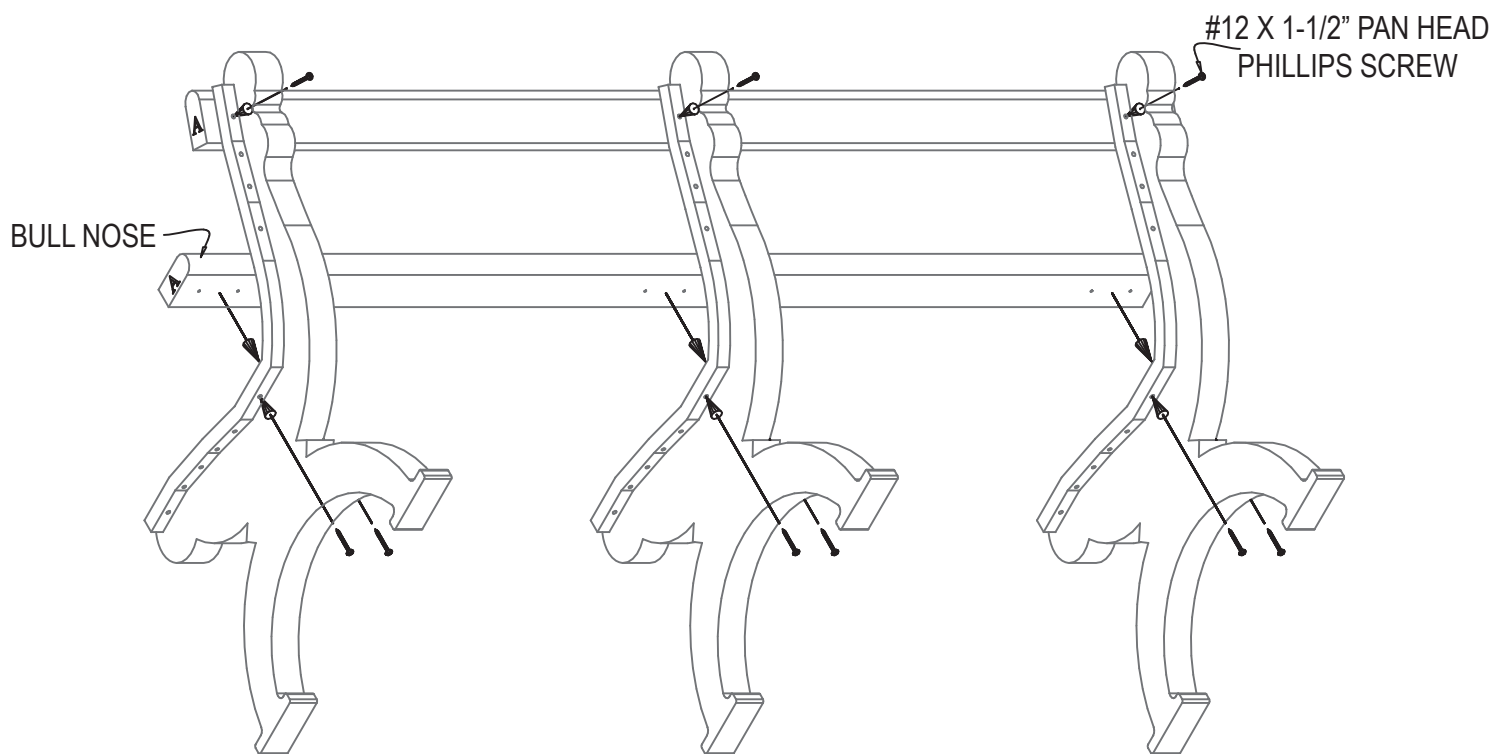

STEP #4:

PLACE A BULL NOSE BENCH BOARD (A) ON POSITION 5. REPEAT STEPS 1 - 3 TO ATTACH. USE (1) ONE #12 X 1-1/2" PAN HEAD PHILLIPS SCREW PER HOLE TO FASTEN.

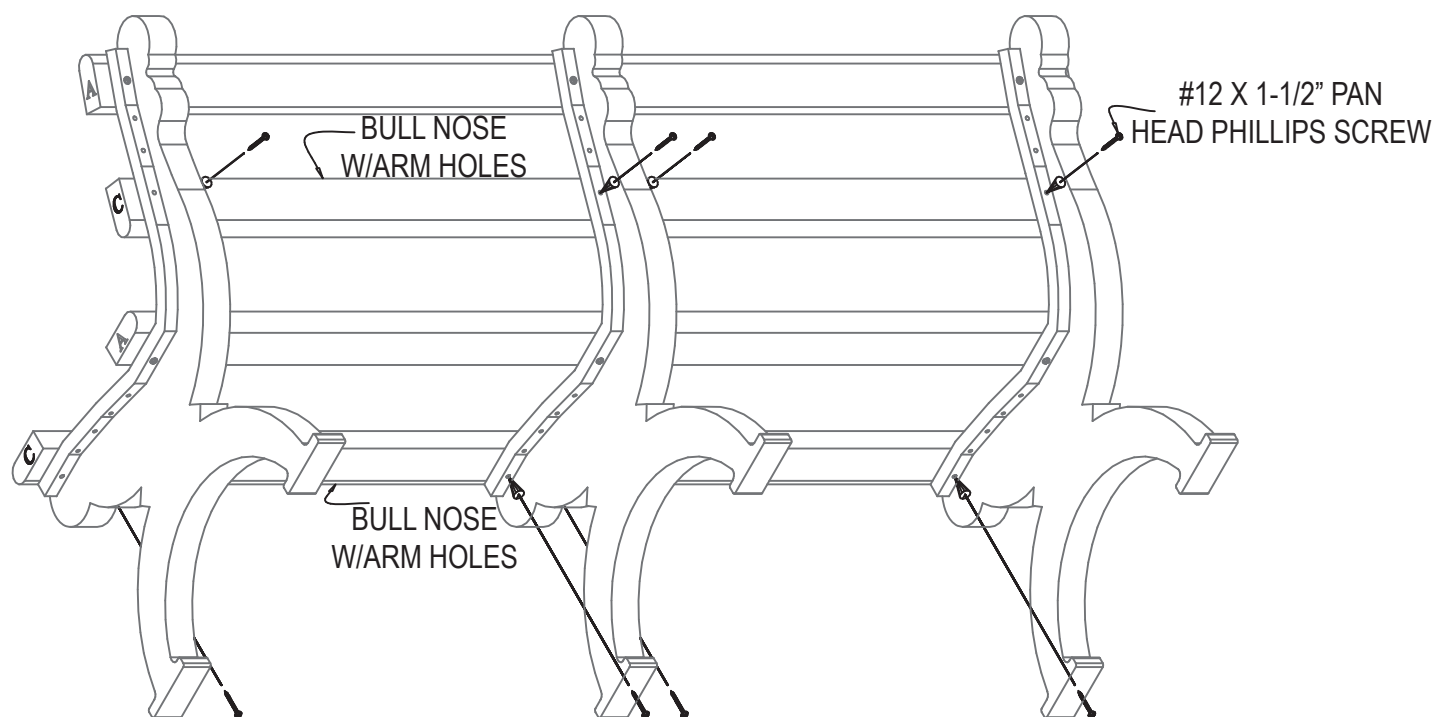

STEP #5:

REPEAT STEPS 1 - 3 TO ATTACH BULL NOSE BENCH BOARDS W/ARM HOLES (C) ON POSITIONS 4 & 10. USE (1) ONE #12 X 1-1/2" PAN HEAD PHILLIPS SCREW PER HOLE TO FASTEN WITH THE EXCEPTION OF THE ARM HOLES.

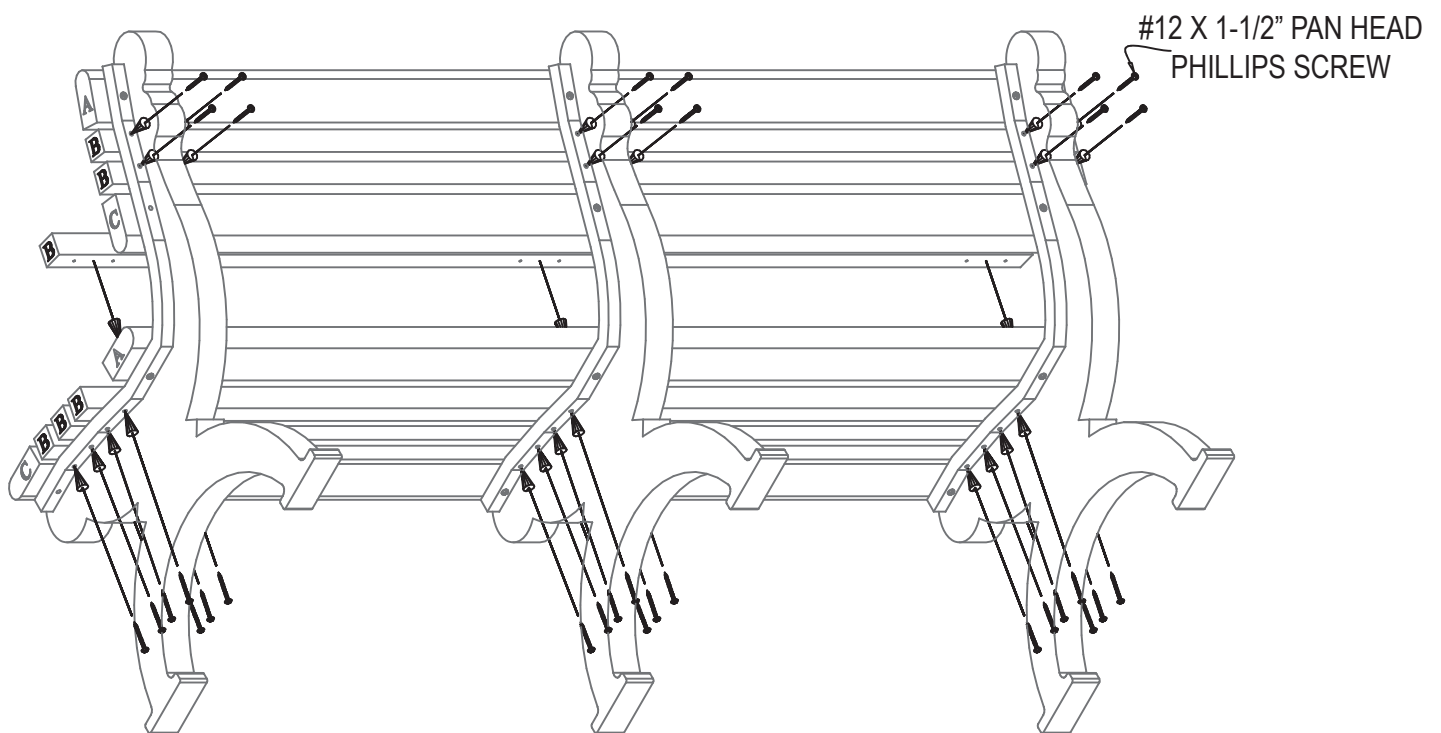

STEP #6:

REPEAT STEPS 1 - 3 TO ATTACH BENCH BOARDS (B) ON POSITIONS 2, 3, 6, 7, 8, & 9. USE (1) ONE #12 X 1-1/2" PAN HEAD PHILLIPS SCREW PER HOLE TO FASTEN.