

Model # CBPB-6CB-BK

Instruction Sheet

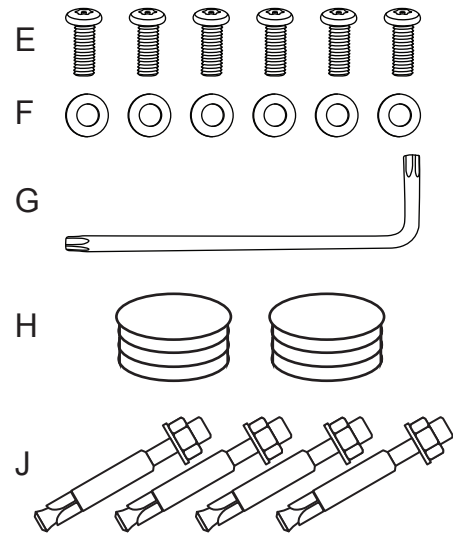
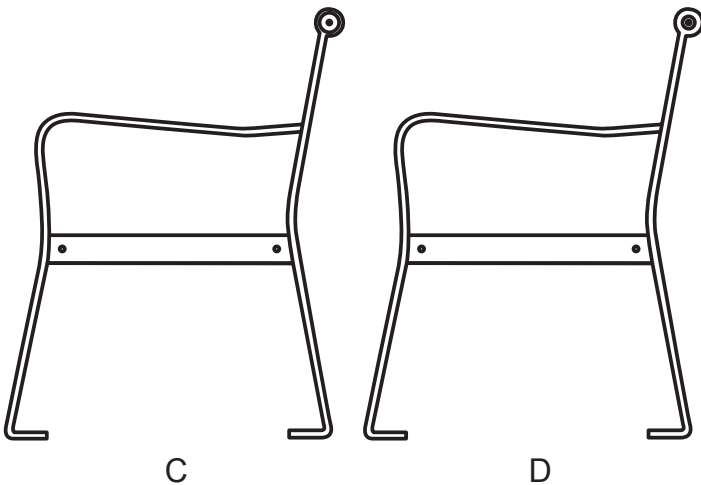
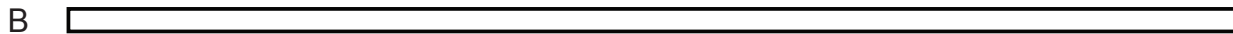
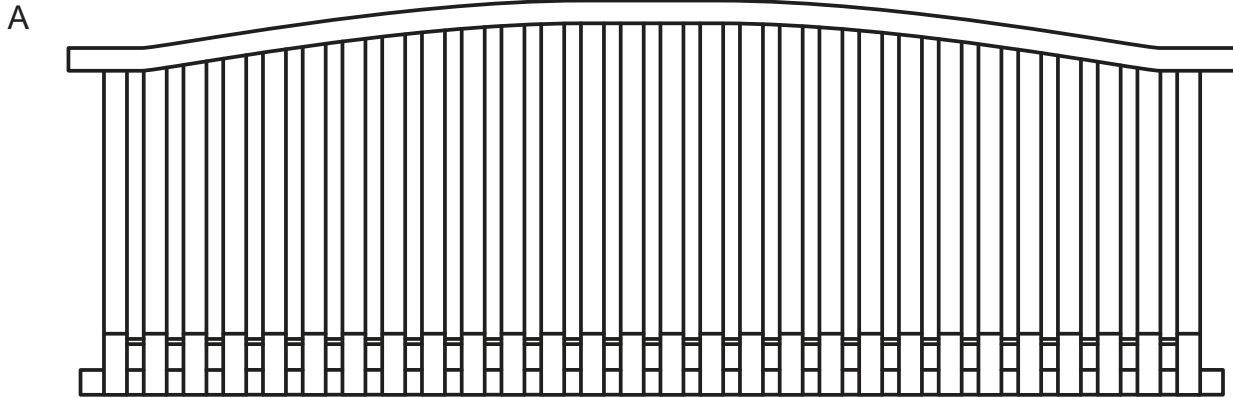

BEFORE ASSEMBLY, PLEASE MAKE SURE ALL COMPONENTS ARE INCLUDED

- A (1) SEAT ASSEMBLY
- B (1) SUPPORT BAR
- C (1) RIGHT END FRAME
- D (1) LEFT END FRAME

- E (6) STAINLESS STEEL TORX BOLTS
- F (6) STAINLESS STEEL WASHERS
- G (1) SECURITY TORX WRENCH
- H (2) END FRAME SOCKET CAPS
- J (4) M8x80 EXPAND ANCHOR BOLTS

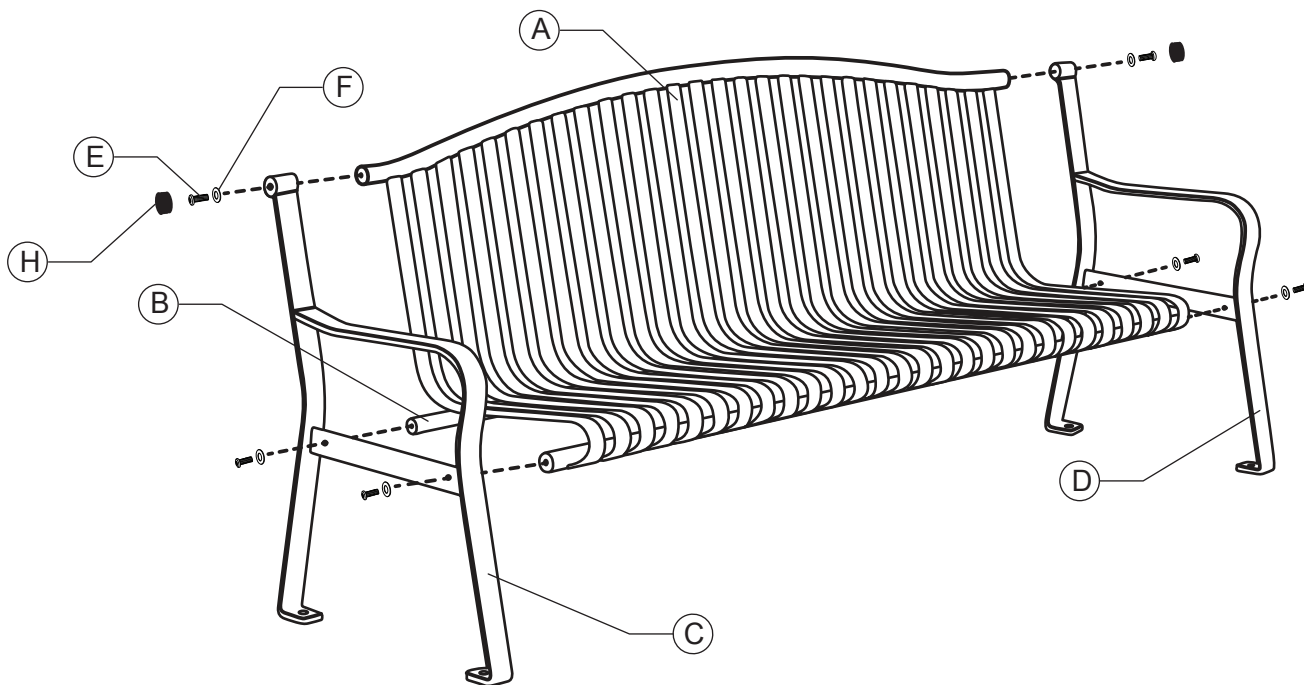

Make sure to assemble the bench on a soft mat to prevent scratching of the product's surface.
DURING ASSEMBLY, DO NOT TIGHTEN BOLTS COMPLETELY.

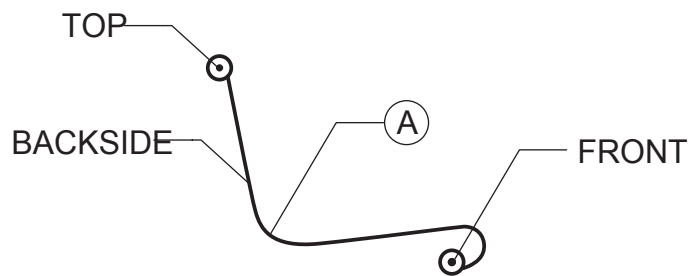

- Step 1: Start by positioning the seat assembly (A) on its backside for ease of assembly.
- Step 2: Raise up the front of the seat assembly (A) to align with the bolt hole at the front of the end frame (C) and attach the end frame to the seat using one torx bolt (E) and washer (F), do not tighten bolt completely. Slide the upper sleeve of the end frame (C) over the backrest extension at the top of the seat assembly (A). Insert one torx bolt (E) with washer (F) into the pre-tapped hole at the top of the end frame to hold securely, but do not tighten.
- Step 3: Repeat Step 2 on other side of the bench using end frame (D), but do not tighten bolts completely yet.
- Step 4: Place the support bar (B) under the seat assembly between the end frames, and align it with the pre-drilled holes in the back of each end frame. Screw in remaining bolts enough to hold securely, but do not tighten.
- Step 5: Position the bench upright and carefully adjust the components to make sure that the bench is square and level. Finally, tighten the bolts to a snug fit.
- Step 6: Optional end frame socket caps (H) are included to insert into end frame sockets.

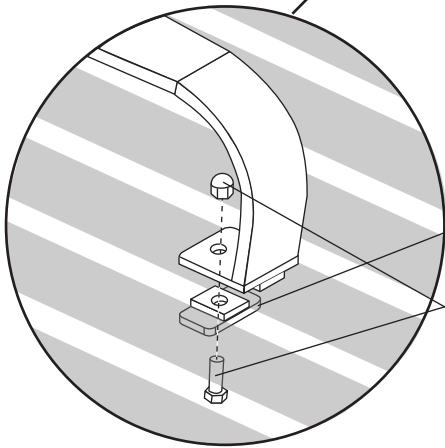
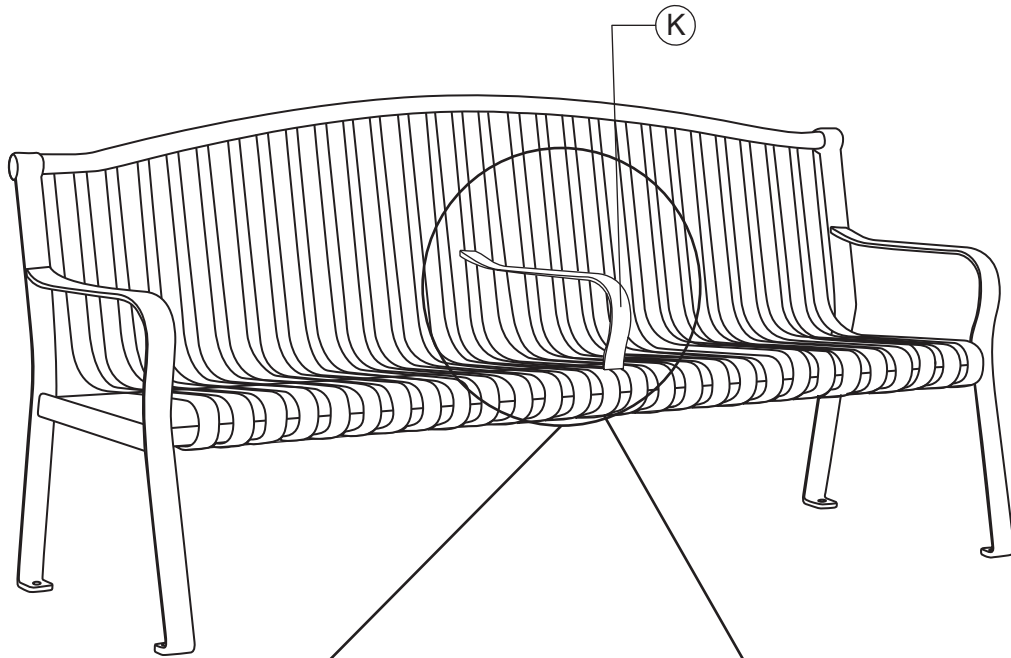

BOTTOM OF ARM

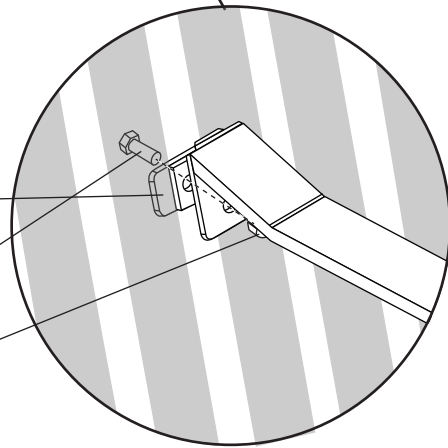

TOP OF ARM

L
M
N

OPTIONAL CENTER ARM ASSEMBLY

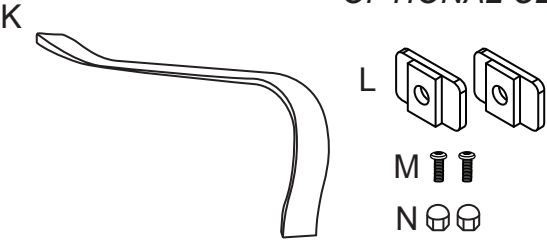

- K (1) CENTER ARM
- L (2) CENTER ARM BACKPLATES
- M (2) STAINLESS STEEL HEX BOLTS
- N (2) STAINLESS STEEL NUTS

Optional Center Arm Installation

Step 1

Place Optional Armrest(K) on the center of the seat lining up bolt holes with gaps in the seat.

Step 2

Line up Arm Backplate(L) in gap with Top of Center Arm(K).

Step 3

Insert Hex Bolt(M) through bolt holes from back to front. Secure with Nut(N) and tighten.

Step 4

Line up Arm Backplate(L) in gap with Bottom of Center Arm(K).

Step 5

Insert Hex Bolt(M) through bolt holes from bottom to top. Secure with Nut(N) and tighten.