

Model # CBPB-6NB-BK

Instruction Sheet

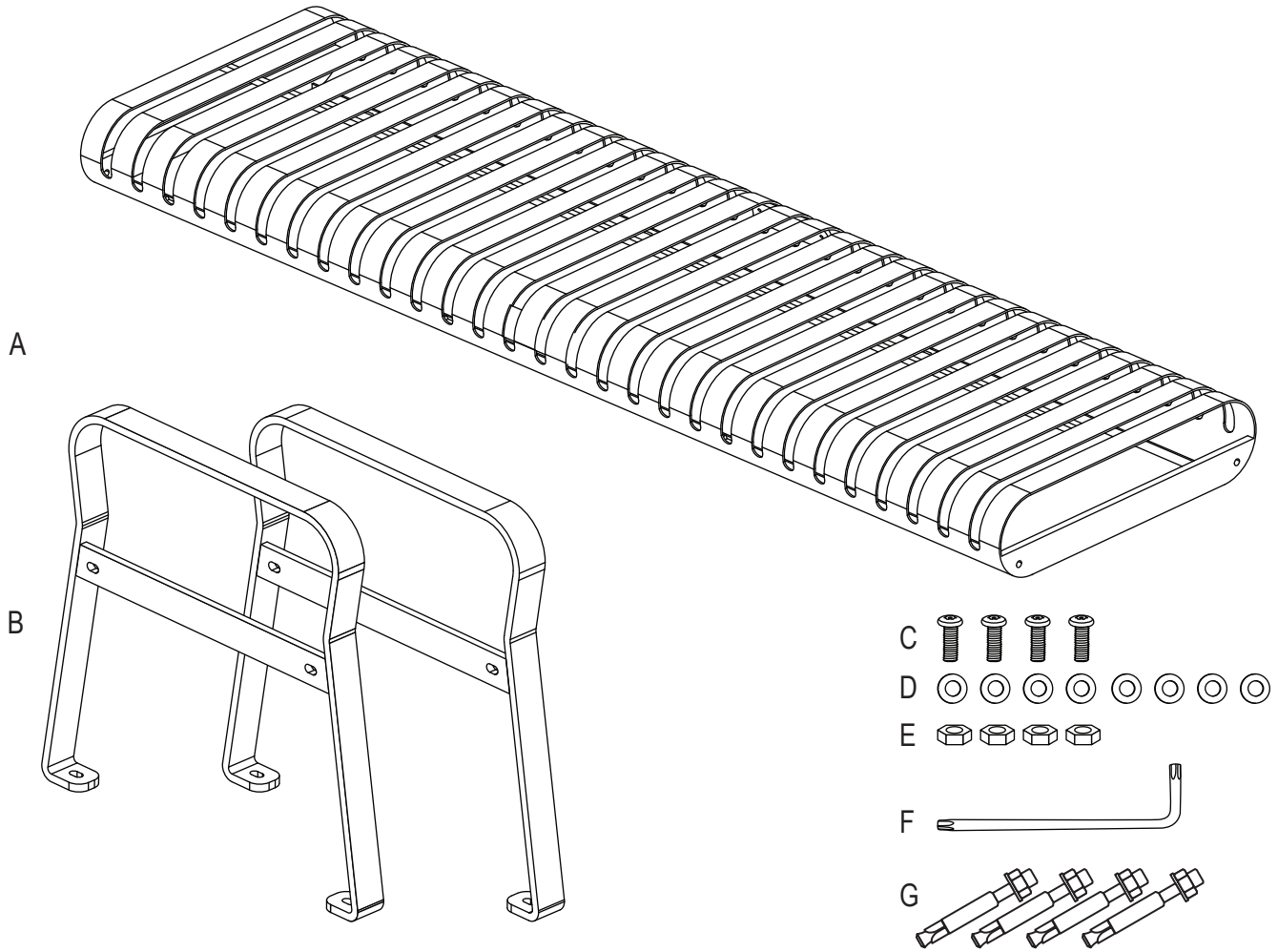

BEFORE ASSEMBLY, PLEASE MAKE SURE ALL COMPONENTS ARE INCLUDED

- |   |   |
|---|---|
| A <input type="checkbox"/> (1) SEAT ASSEMBLY        | C <input type="checkbox"/> (4) STAINLESS STEEL TORX BOLTS |
| B <input type="checkbox"/> (2) UNIVERSAL END FRAMES | D <input type="checkbox"/> (8) STAINLESS STEEL WASHERS    |
|   | E <input type="checkbox"/> (4) STAINLESS STEEL NUTS       |
|   | F <input type="checkbox"/> (1) SECURITY TORX WRENCH       |
|   | G <input type="checkbox"/> (4) M8x80 EXPAND ANCHOR BOLTS  |

**OPTIONAL CENTER ARM ASSEMBLY**

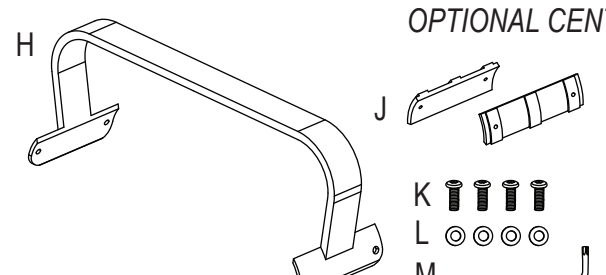

H <input type="checkbox"/> (1) CENTER ARM
J <input type="checkbox"/> (2) CENTER ARM BACKPLATES
K <input type="checkbox"/> (4) STAINLESS STEEL HEX BOLTS
L <input type="checkbox"/> (4) STAINLESS STEEL WASHERS
M <input type="checkbox"/> (1) HEX WRENCH

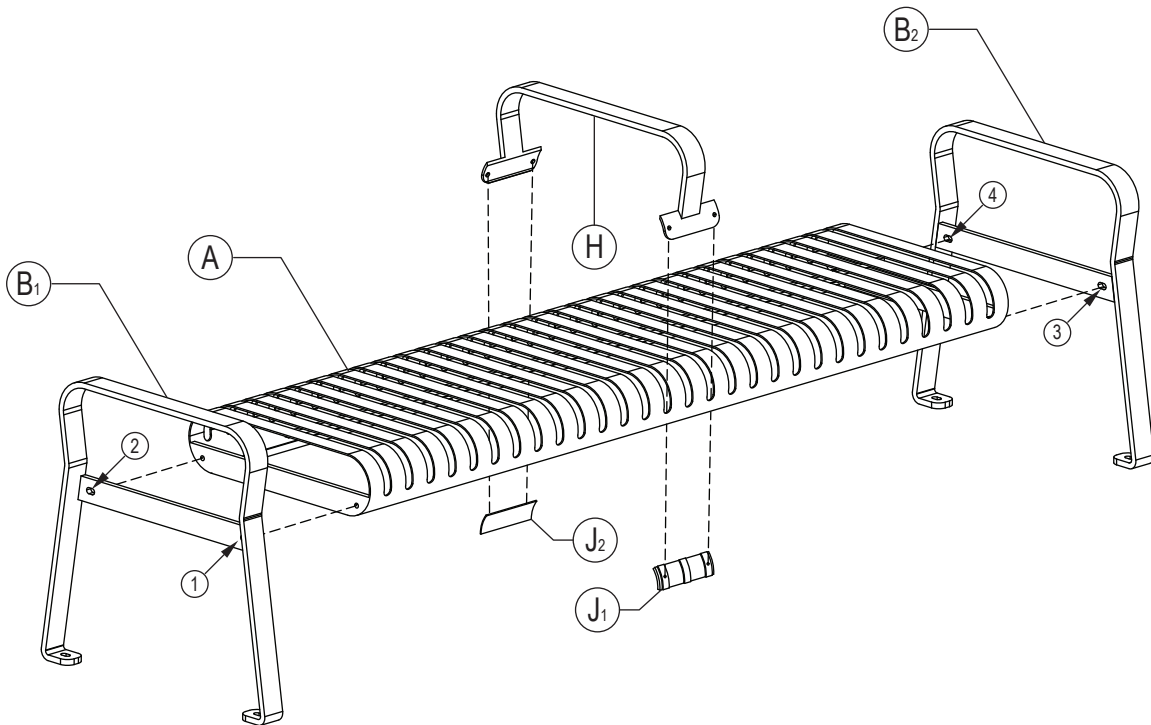

*Make sure to assemble the bench on a soft mat to prevent scratching of the product's surface.*

***DURING ASSEMBLY, DO NOT TIGHTEN BOLTS COMPLETELY.***

### **Bench Assembly**

#### **Step 1**

Place one End Frame(B) at each end of Bench Seat Assembly(A).

#### **Step 2**

With the legs (Part B) laying on their side, line up the holes from the Bench Seat Assembly(A) ends and loosely insert Torx Bolts(C) and Washers(D) from the outside of each End Frame(B) and add Washers(D) and Nuts(E) on the inside of Bench Seat Assembly(A).

#### **Step 3**

Stand bench upright on flat surface, level, then tighten all 4 Torx Bolts(C).

### **Optional Center Arm Installation**

#### **Step 1**

Place Optional Armrest(H) on the center of the seat lining up the bolt holes to line up with the gaps in the seat.

#### **Step 2**

Insert Hex Bolts(K) and Washers(L) into the Armrest holes through the bench.

#### **Step 3**

Hold Center Arm Backplate(J) under seat lining up with the Hex Bolts(K) and tighten.

### **Surface Installation**

#### **Step 1**

Choose your desired location for the bench, then use a marker, chalk, or pencil to outline the holes of the frame onto the base material.

#### **Step 2**

Move bench and drill 4 x 3/8" diameter holes at 3.0" depth. Place Expand Anchor Bolts(G) in holes.

#### **Step 3**

Remove Nuts (E) and Washers (D) and carefully set bench over the Expanded Anchor Bolts(G) through the holes of the bench feet.

#### **Step 4**

Place Washers(D) and Nuts(E) on the Expanded Anchor Bolts(G) then tighten. Make sure to keep Expanded Anchor Bolts(G) fully recessed while tightening until set, do not over-tighten.