

Model # HT-100

Instructions Sheet

WALK-THROUGH HEXAGON PICNIC TABLE

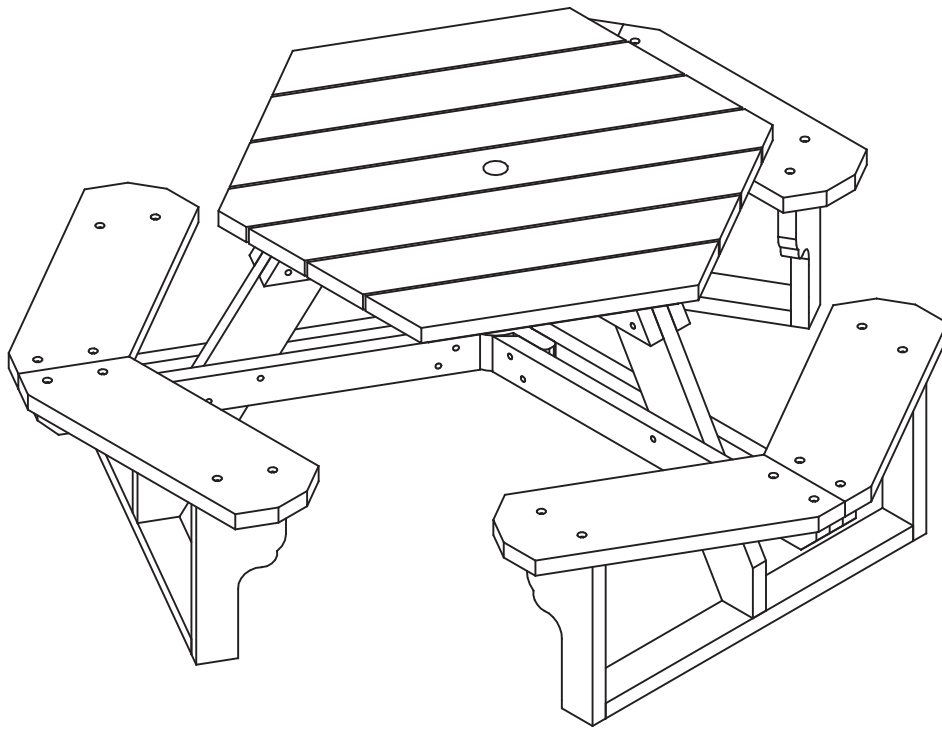

BEFORE ASSEMBLY, PLEASE MAKE SURE ALL COMPONENTS ARE INCLUDED.

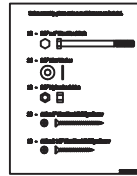
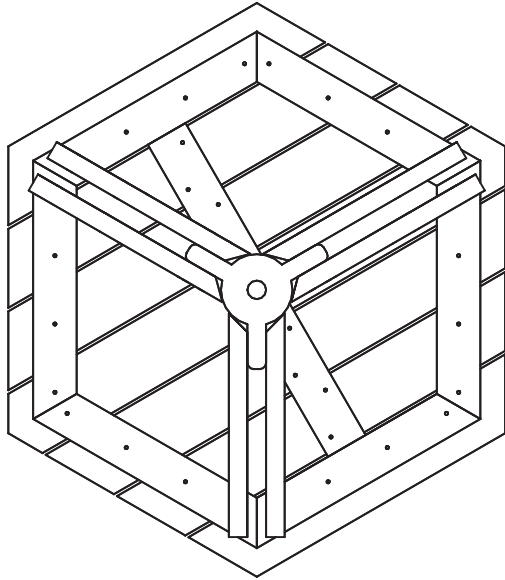

FP - FASTENER PACK
(1) - ONE FASTENER PACK

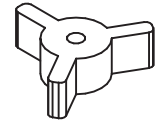

R - CENTER PROPELLER
(1) - ONE CENTER PROPELLER

J - TABLE TOP
(1) - ONE TABLE TOP W/SMALL SPOKE ASSEMBLY

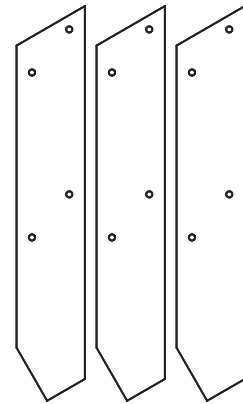

H - LEG
(3) - THREE LEGS

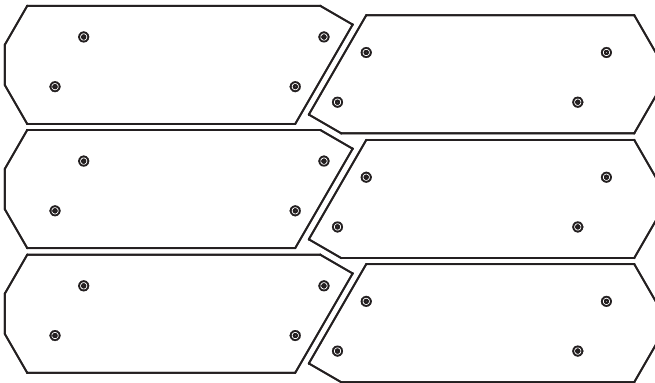

N - SEAT
(6) - SIX SEATS

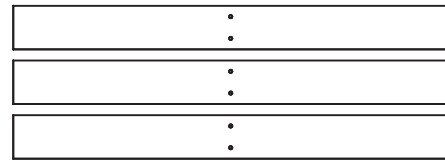

A - LEG SUPPORT
(3) - THREE LEG SUPPORTS

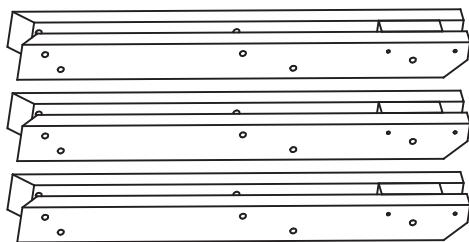

C - LARGE SPOKE
(3) - THREE LARGE SPOKES

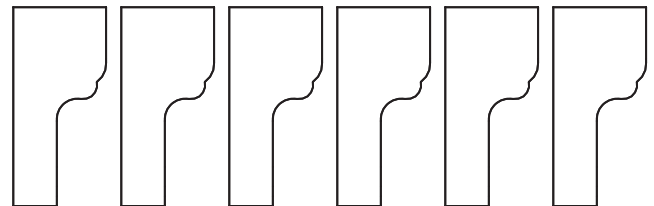

Q - SEAT SUPPORT
(6) - SIX SEAT SUPPORTS

BEFORE ASSEMBLY, PLEASE MAKE SURE ALL FASTENERS ARE INCLUDED.

18 - 3/8" X 5" HEX HEAD BOLT

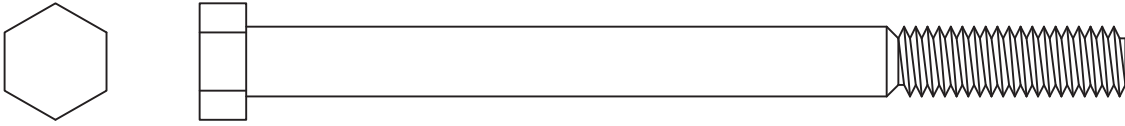

36 - 3/8" FLAT WASHER

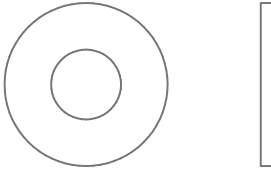

18 - 3/8" NYLON LOCK NUT



30 - #12 X 3" FLAT HEAD PHILLIPS SCREW



12 - #12 X 2-1/2" FLAT HEAD PHILLIPS SCREW



ALSO NEEDED FOR THIS ASSEMBLY WILL BE THE FOLLOWING MATERIALS:

1 - #3 PHILLIPS DRIVE BIT

2 - 9/16" SOCKET WRENCH

STEP #1:

FASTEN (2) TWO SEAT SUPPORTS ONTO EACH END OF (1) ONE LEG SUPPORT. BE SURE THAT EACH SEAT SUPPORT, WHEN FASTENED, ARE POINTING IN THE SAME DIRECTION AS SHOWN ABOVE. USE (1) ONE #12 X 2-1/2" FLAT HEAD PHILLIPS SCREW PER HOLE TO SECURE.

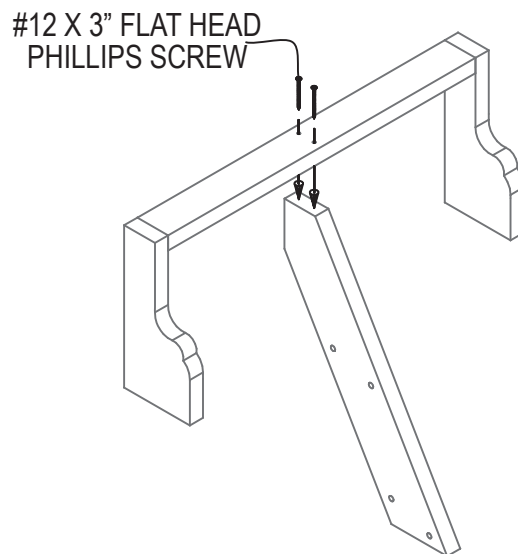
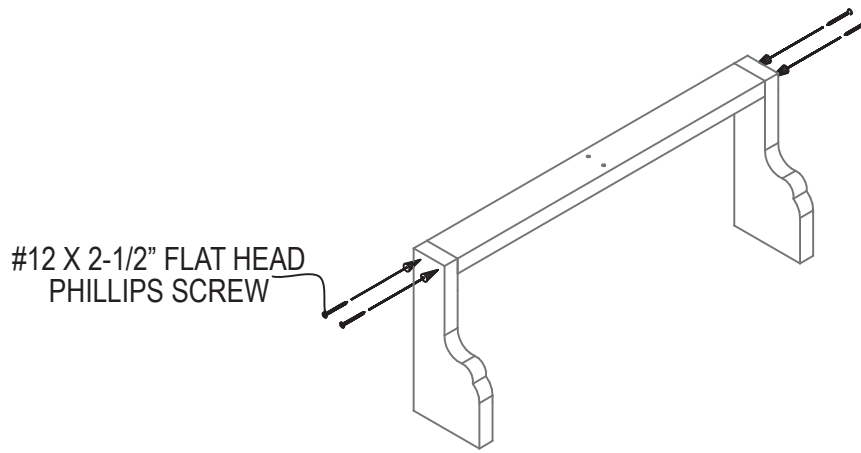

STEP #2:

FASTEN THE SEAT SUPPORT ASSEMBLY TO THE LEG AS SHOWN ABOVE. USE (1) ONE #12 X 3" FLAT HEAD PHILLIPS SCREW PER HOLE TO SECURE.

STEP #3:

SLIDE THE LARGE SPOKE ASSEMBLY UP TO MATCH THE HOLES TO THE LEGS. SECURE THE LARGE SPOKE ASSEMBLY TO THE LEGS AS SHOWN BELOW. USE (1) ONE 3/8" X 5" HEX HEAD BOLT AND (1) ONE 3/8" FLAT WASHER ALONG WITH (1) ONE 3/8" FLAT WASHER AND (1) ONE 3/8" NYLON LOCK NUT PER HOLE TO SECURE.

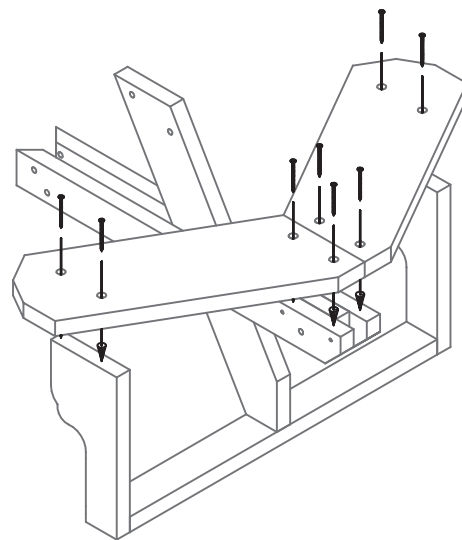
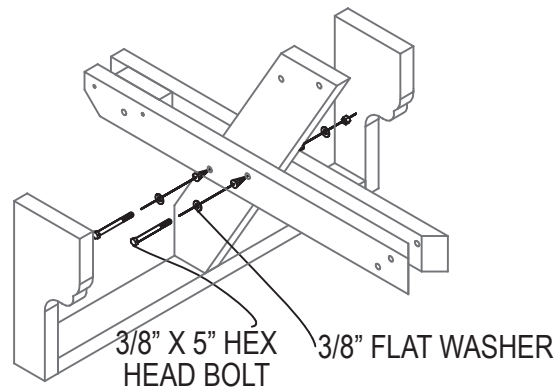

STEP #4:

FASTEN THE SEATS TO THE LARGE SPOKE ASSEMBLY USING THE PROVIDED PILOT HOLES AND SEAT SUPPORT ASSEMBLIES, AS SHOWN ABOVE. BE SURE WHEN INSTALLING THE SET OF SEATS THAT THE INNER EDGES ARE FLUSH AND TIGHT WITH EACH OTHER. USE (1) ONE #12 X 3" FLAT HEAD PHILLIPS SCREW PER HOLE TO SECURE.

STEP #5: REPEAT STEPS 1 THROUGH 4, TWO TIMES.

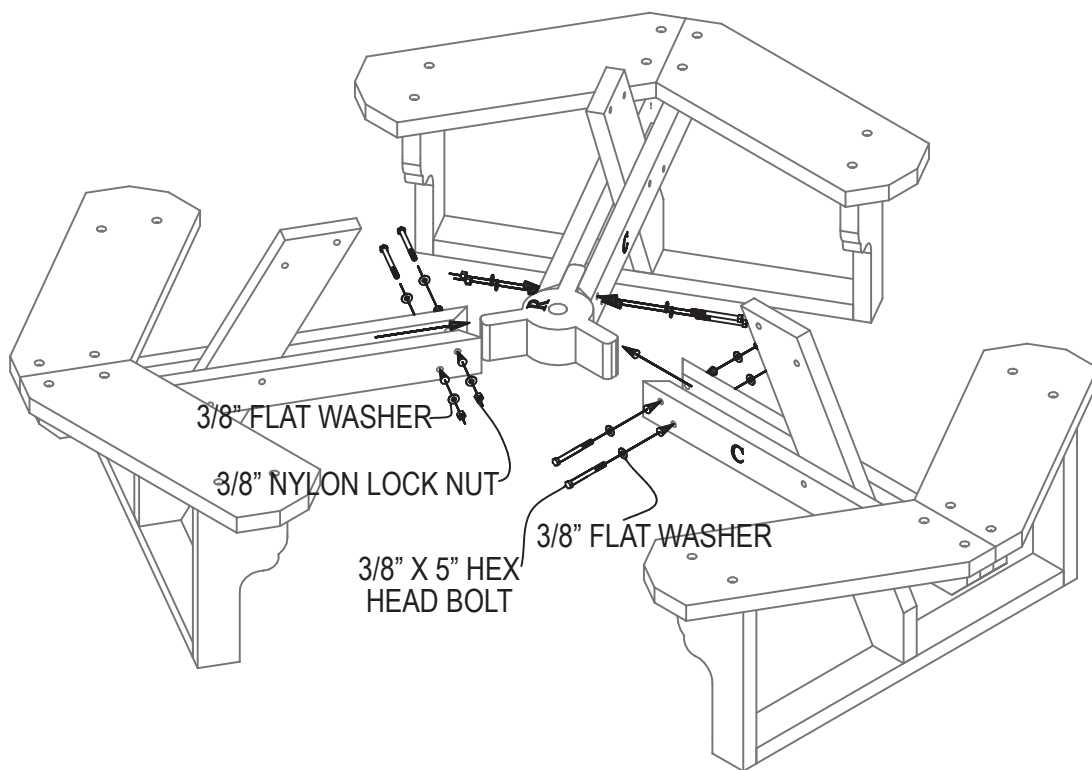

STEP #6:

ASSEMBLE THE LEG/SEAT ASSEMBLIES TO THE CENTER PROPELLER AS SHOWN ABOVE. USE (1) ONE 3/8" X 5" HEX HEAD BOLT AND (1) ONE 3/8" FLAT WASHER ALONG WITH (1) ONE 3/8" FLAT WASHER AND (1) ONE 3/8" NYLON LOCK NUT PER HOLE TO SECURE.

DO NOT TIGHTEN BOLTS COMPLETELY. THIS WILL BE DONE IN A LATER STEP.

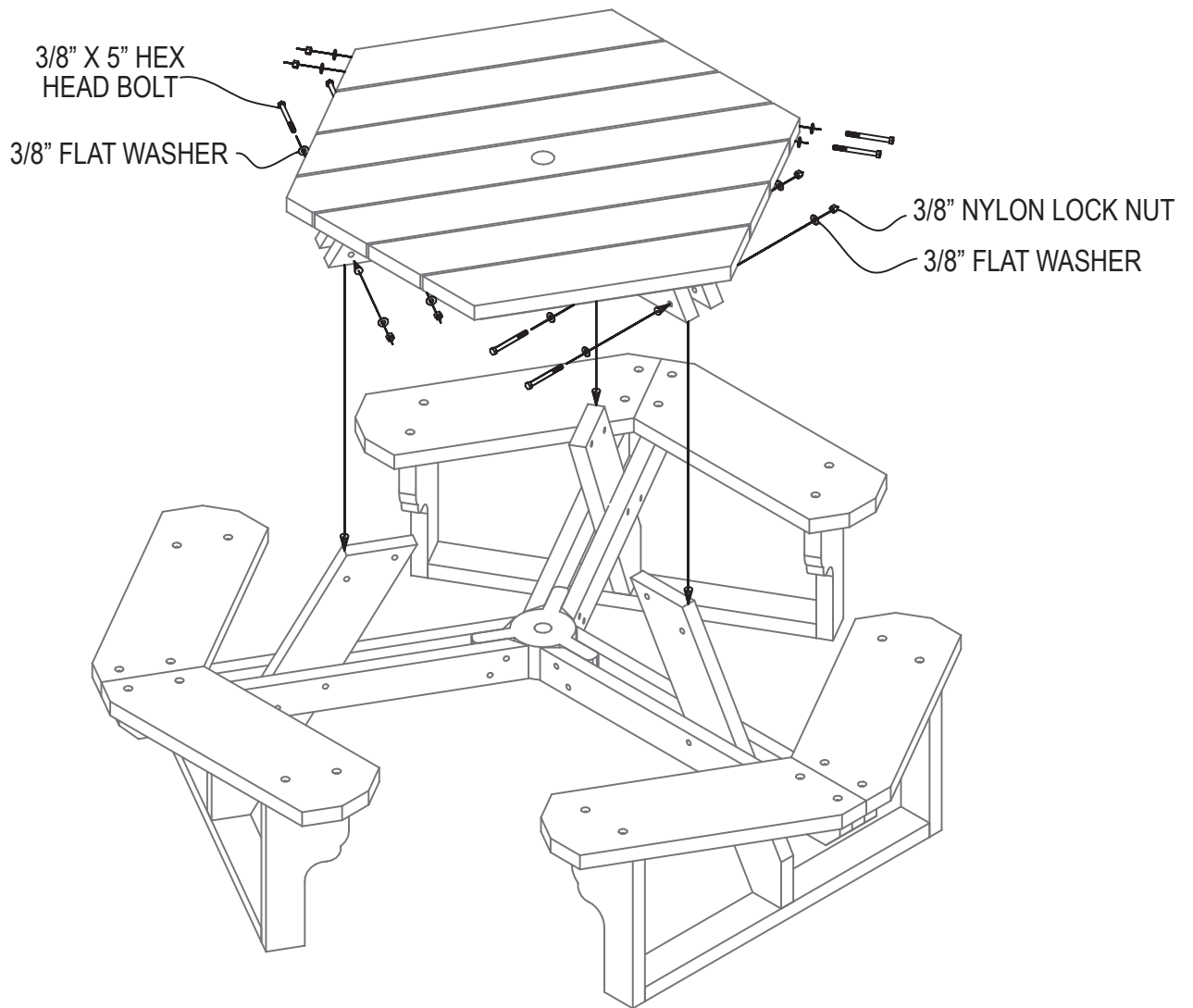

STEP #7:

PLACE THE TABLE TOP ASSEMBLY ONTO THE LEG/SEAT ASSEMBLIES AS SHOWN ABOVE. SLIDE (1) ONE LEG BETWEEN THE PROPELLERS OF EACH SPOKE ASSEMBLY. SECURE THE LEGS TO THE SMALL SPOKE ASSEMBLY. USE (1) ONE 3/8" X 5" HEX HEAD BOLT AND (1) ONE 3/8" FLAT WASHER ALONG WITH (1) ONE 3/8" FLAT WASHER AND (1) ONE 3/8" NYLON LOCK NUT PER HOLE TO SECURE. BE SURE TO TIGHTEN ALL LOOSE BOLTS AFTER COMPLETING THIS STEP.