

Model # HT-100Y

Instructions Sheet

RECYCLED PLASTIC HEXAGON KIDS PICNIC TABLE

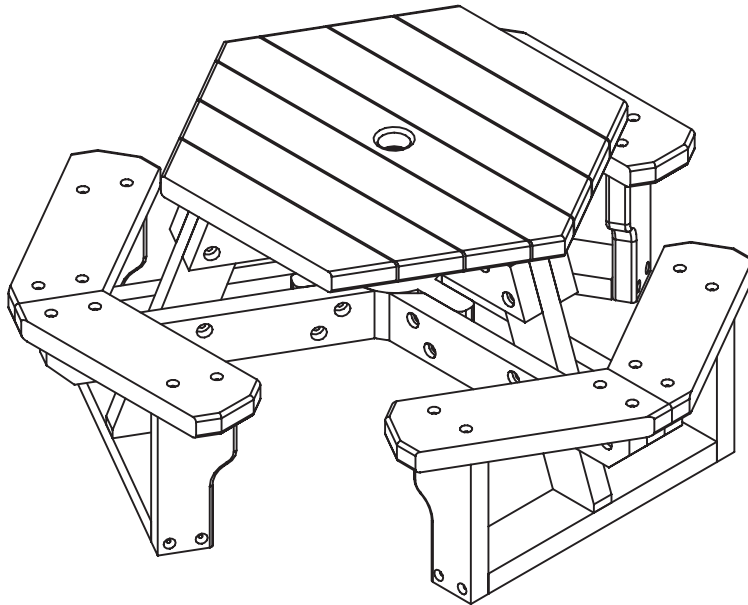

BEFORE ASSEMBLY, PLEASE MAKE SURE ALL COMPONENTS ARE INCLUDED.

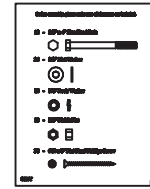
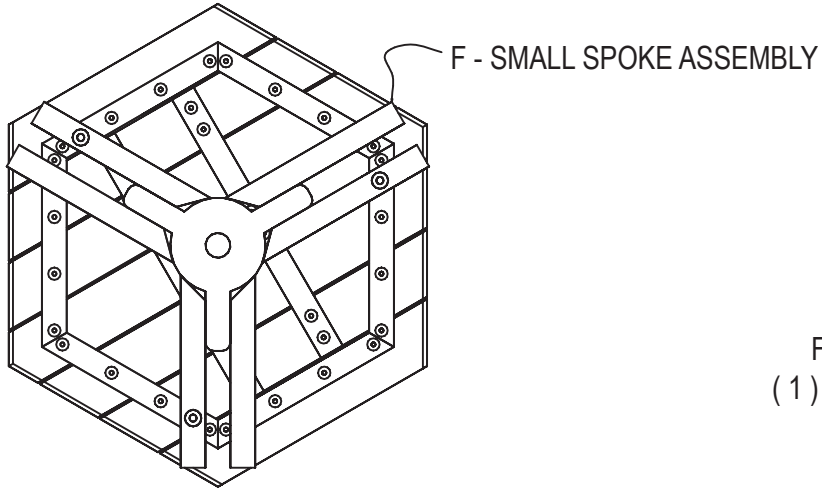

FP - FASTENER PACK
(1) - ONE FASTENER PACK

J - TABLE TOP
(1) ONE TABLE TOP W/ SMALL SPOKE ASSEMBLY

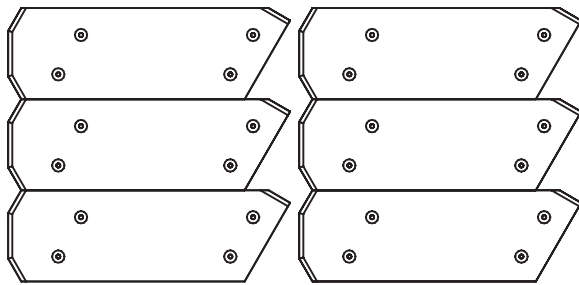

N - SEAT
(6) - SIX SEATS

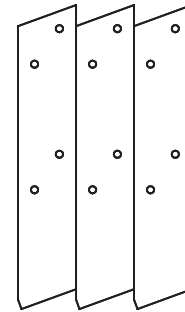

H - LEG
(3) - THREE LEGS

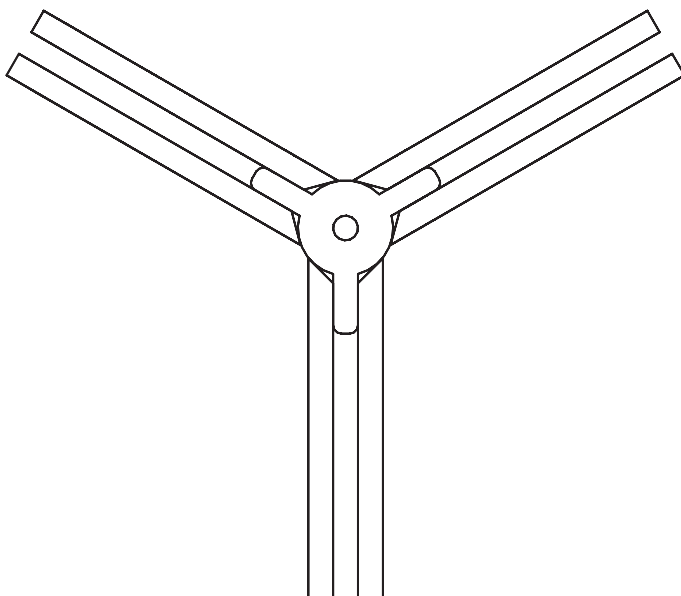

(1) - ONE LARGE PROPELLAR ASSEMBLY

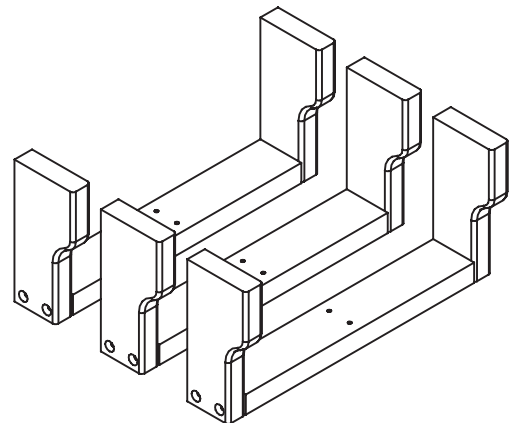

A - SEAT SUPPORT ASSEMBLY
(3) THREE SEAT SUPPORTS

BEFORE ASSEMBLY, PLEASE MAKE SURE ALL FASTENERS ARE INCLUDED.

12 - 3/8" X 5" HEX HEAD BOLT

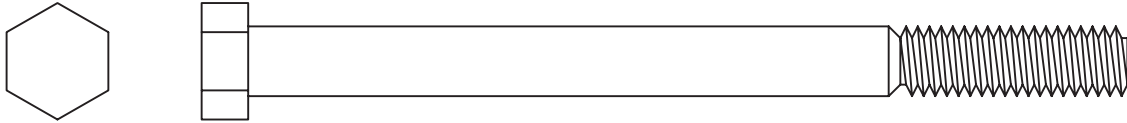

24 - 3/8" FLAT WASHER

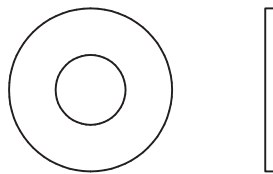

12 - 3/8" NYLON LOCK NUT

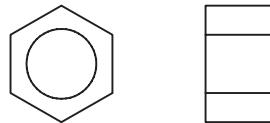

30 - #12 X 3" FLAT HEAD PHILLIPS SCREW



ALSO NEED FOR THIS ASSEMBLY WILL BE THE FOLLOWING MATERIALS:

- 1 - #3 PHILLIPS DRIVE BIT
- 2 - 9/16" SOCKET WRENCH

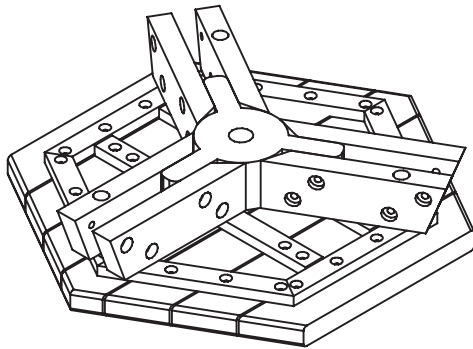

STEP #1:
PLACE THE TABLE TOP UPSIDE DOWN WITH THE SMALL SPOKE ASSEMBLY FACING UP TO BEGIN ASSEMBLY.

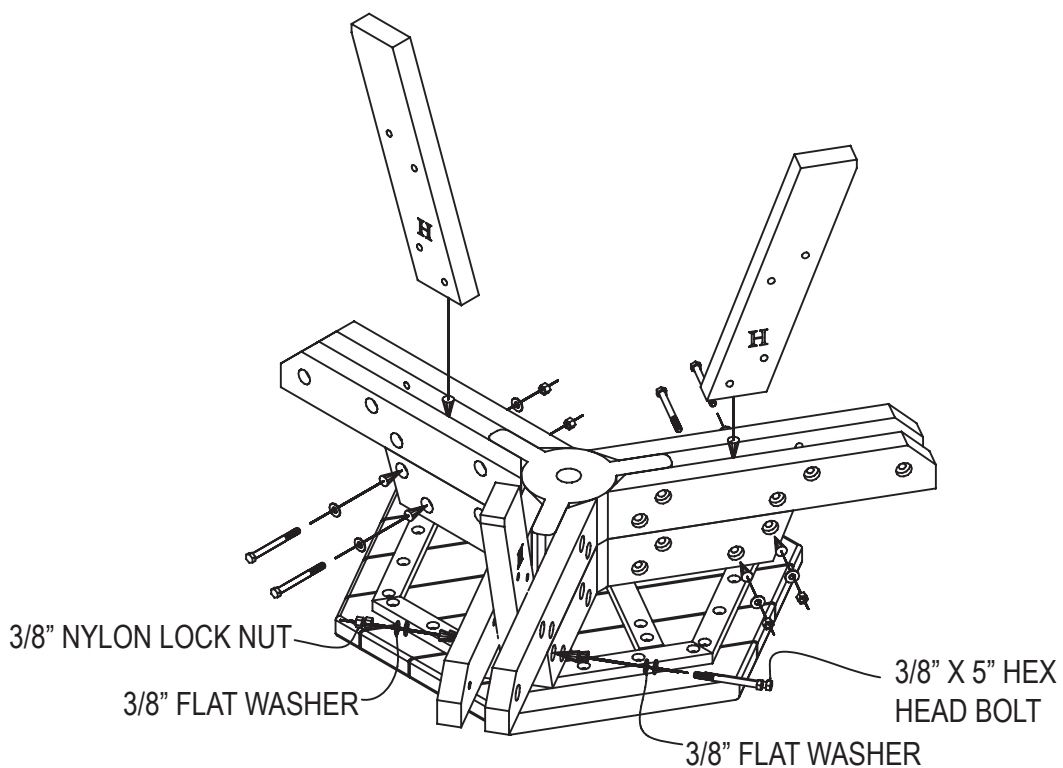

STEP #2:

WHILE THE TABLE IS UPSIDE DOWN, PLACE THE LARGE SPOKE ASSEMBLY ONTO THE SMALL SPOKE ASSEMBLY AS SHOWN ABOVE. SLIDE (1) ONE LEG BETWEEN THE PROPELLERS OF EACH SPOKE ASSEMBLY. SECURE THE LEGS TO THE SMALL SPOKE ASSEMBLY. USE (1) ONE 3/8" X 5" HEX HEAD BOLT AND (1) ONE 3/8" FLAT WASHER ALONG WITH (1) ONE 3/8" FLAT WASHER, AND (1) ONE 3/8" NYLON LOCK NUT PER HOLE TO SECURE.

DO NOT TIGHTEN BOLTS COMPLETELY. THIS WILL BE DONE IN A LATER STEP.

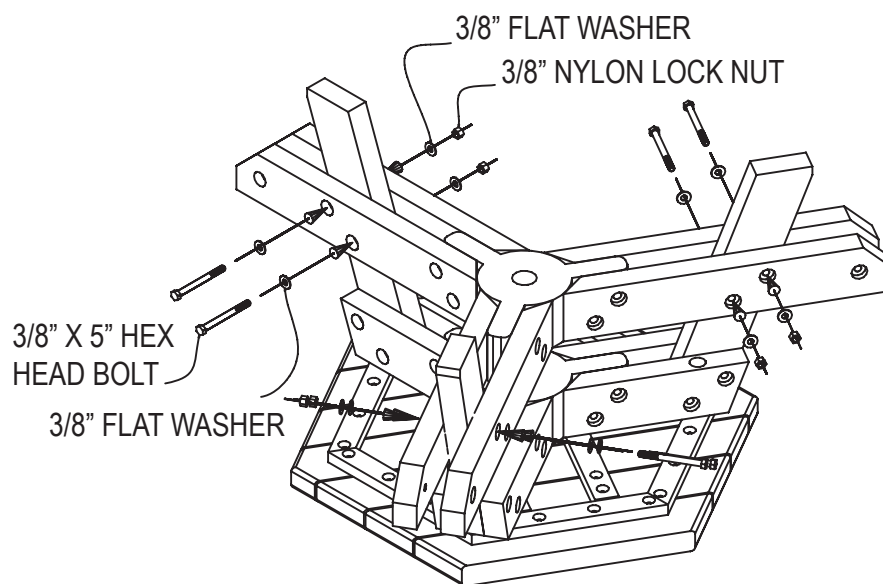

STEP #3:

WHILE THE TABLE IS UPSIDE DOWN, SLIDE THE LARGE SPOKE ASSEMBLY UP TO MATCH THE HOLES TO THE LEGS. SECURE THE LARGE SPOKE ASSEMBLY TO THE LEGS AS SHOWN ABOVE. USE (1) ONE 3/8" X 5" HEX HEAD BOLT AND (1) ONE 3/8" FLAT WASHER ALONG WITH (1) ONE 3/8" FLAT WASHER, AND (1) ONE 3/8" NYLON LOCK NUT PER HOLE TO SECURE.

BE SURE TO TIGHTEN ALL LOOSE BOLTS AFTER COMPLETING THIS STEP.

#12 X 3" FLAT HEAD
PHILLIPS SCREW

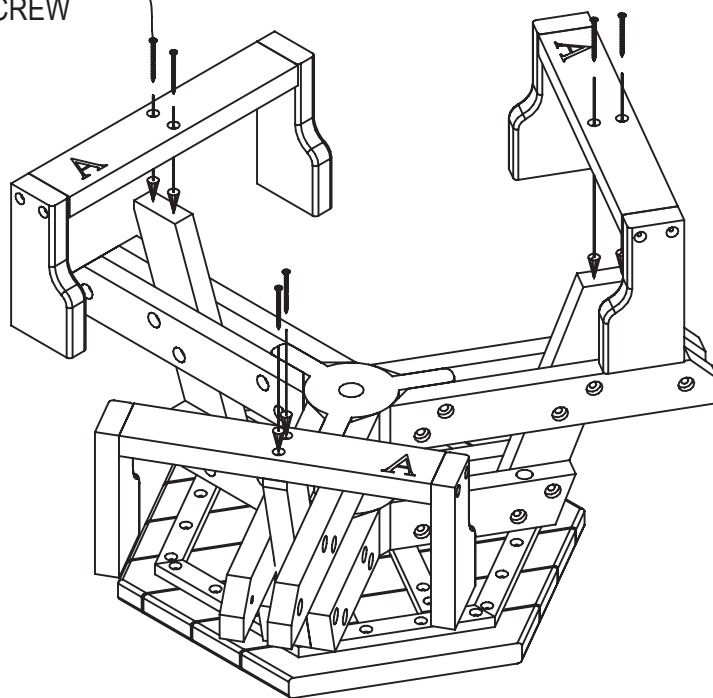

STEP #4:

WHILE THE TABLE IS UPSIDE DOWN, FASTEN THE SEAT SUPPORT ASSEMBLY TO THE LEGS AS SHOWN ABOVE. USE (1) ONE #12 X 3" FLAT HEAD PHILLIPS SCREW PER HOLE TO SECURE.

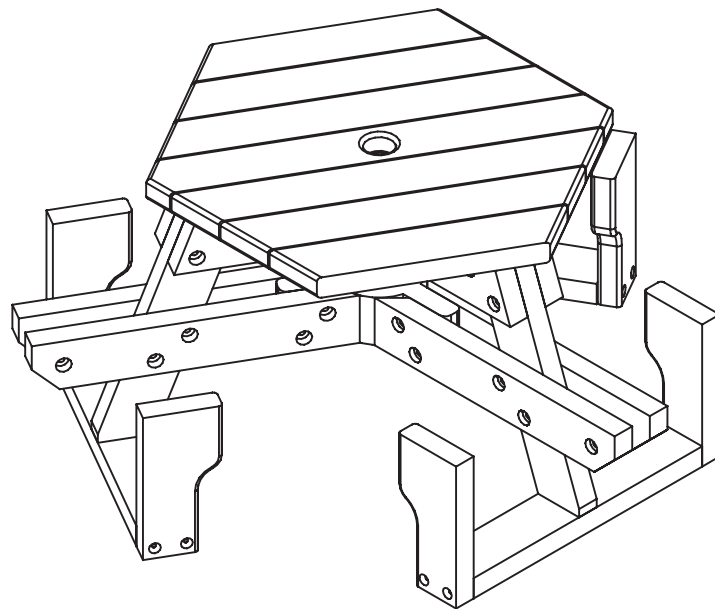

STEP #5:
FLIP THE TABLE UPRIGHT ONTO IT'S FRAME. PLEASE TAKE CAUTION WHILE FLIPPING THE TABLE.
AT THIS POINT IN ASSEMBLY THE TABLE WEIGHS APPROXIMATELY 93 POUNDS.

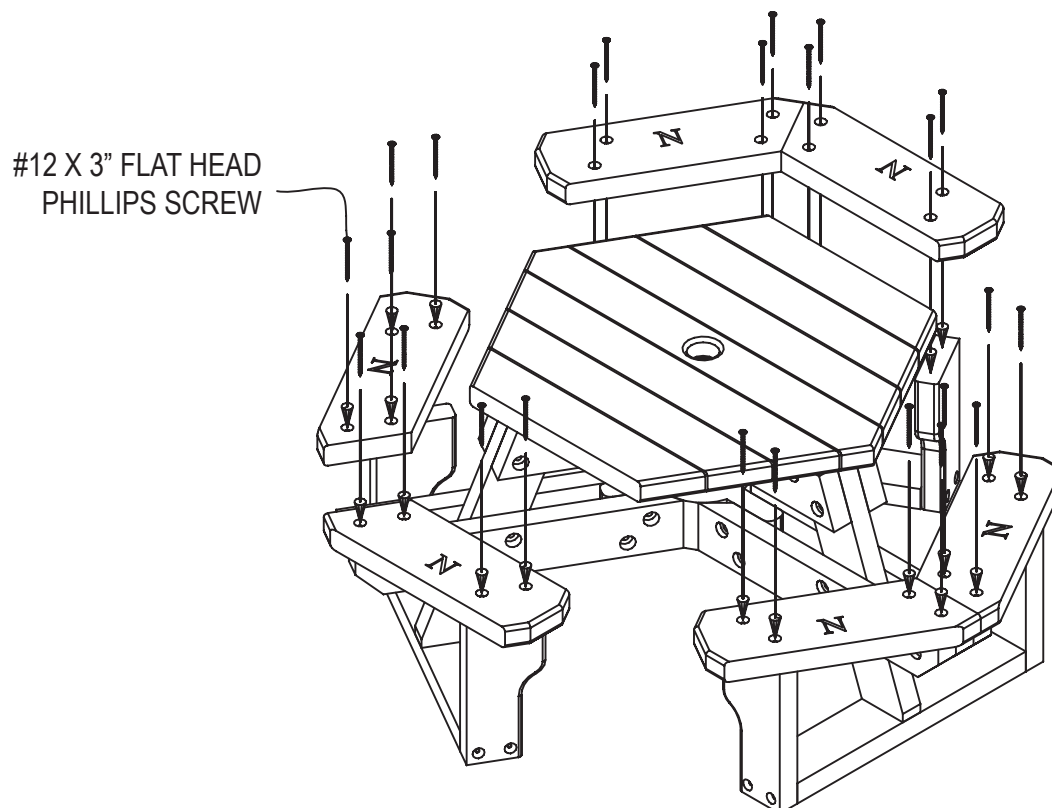

STEP #6:

WHILE THE TABLE TOP IS UPRIGHT, FASTEN THE SEATS TO THE SEATS TO THE LARGE SPOKE ASSEMBLY AND SEAT SUPPORT ASSEMBLIES AS SHOWN ABOVE. BE SURE WHEN INSTALLING EACH SET OF SEATS THAT THE INNER EDGES ARE FLUSH AND TIGHT WITH EACH OTHER. USE (1) ONE #12 X 3" FLAT HEAD PHILLIPS SCREW PER HOLE TO SECURE.