



Principal Plant and General Offices  
627 Amersale Drive  
Naperville, IL 60563

Toll Free: 1-800-323-5664  
Phone: 1-630-897-8489  
Fax: 1-630-897-0573  
Web Site: www.belson.com

## PARK CHIEF

Thank you for buying a BELSON OUTDOORS quality product.

### INDEX

- 1) FRAME KIT CONTENTS
- 2) PLANK KIT CONTENTS AND PLANK REFERENCES
- 3) ALUMINUM 6' AND 8' ASSEMBLY INSTRUCTIONS

### PC-AF FRAME KIT CONTENTS:

#### (2) SUPPORT BRACE

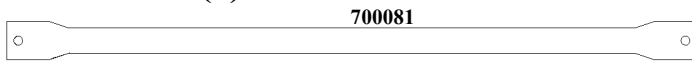

700081

#### (1) HARDWARE BAG

702312

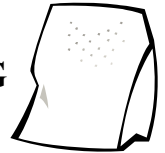

#### (2) TOP "L" BRACKET

700023

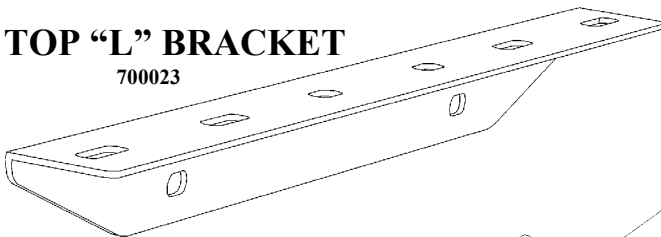

#### (2) SEAT BRACKET

700004

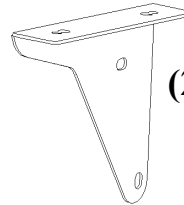

#### (1) CENTER SPACER

700072

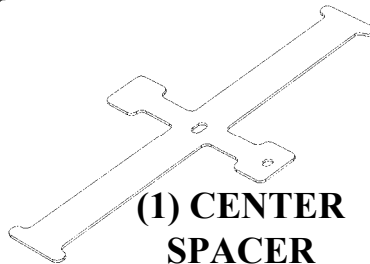

#### (2) SEAT BRACKET

700005

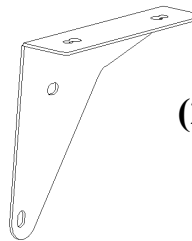

#### (4) PARK CHIEF "J" LEG

700202

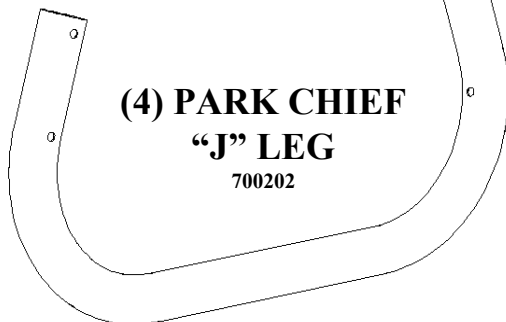

#### (1) CENTER CHANNEL

700063



#### (1) CENTER BRACKET

700043

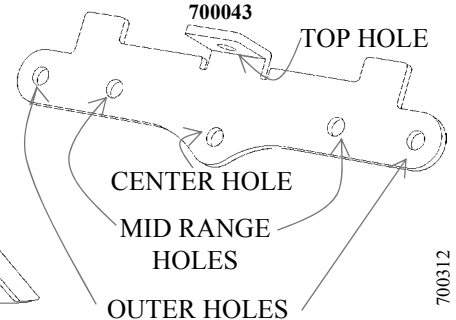

700312

# BELSON ALUMINUM PLANK KIT

## PLANK KIT CONTENTS:

**ALUMINUM PLANK (5)**

TOP VIEW

SIDE VIEW

| 6' ALUMINUM |        |          |
|-------------|--------|----------|
| KELLY GREEN | TAN    | ANODIZED |
| 702171      | 702172 | 702173   |

| 8' ALUMINUM |        |          |
|-------------|--------|----------|
| KELLY GREEN | TAN    | ANODIZED |
| 702161      | 702162 | 702163   |

BOARDS SIZE DEPENDS ON TABLE/KIT MODEL, EITHER 6' OR 8' SEE INSTRUCTIONS FOR ASSEMBLY.

**ANODIZED ALUMINUM  
SEAT END CAP (4)  
702032**

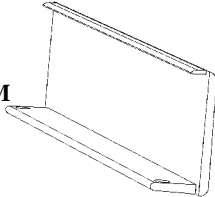

**ANODIZED ALUMINUM  
TABLE TOP END CAP (2)  
702033**

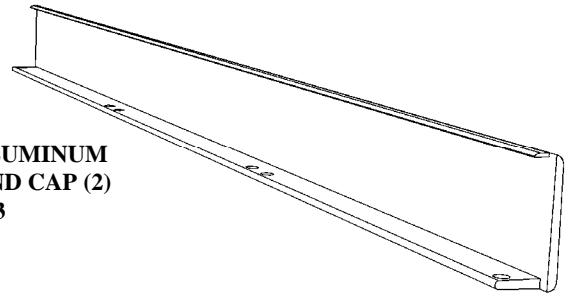

## REFERENCES FOR ALUMINUM PLANKS

**TOOLS NEEDED:** pencil or marker and tape measure or ruler.

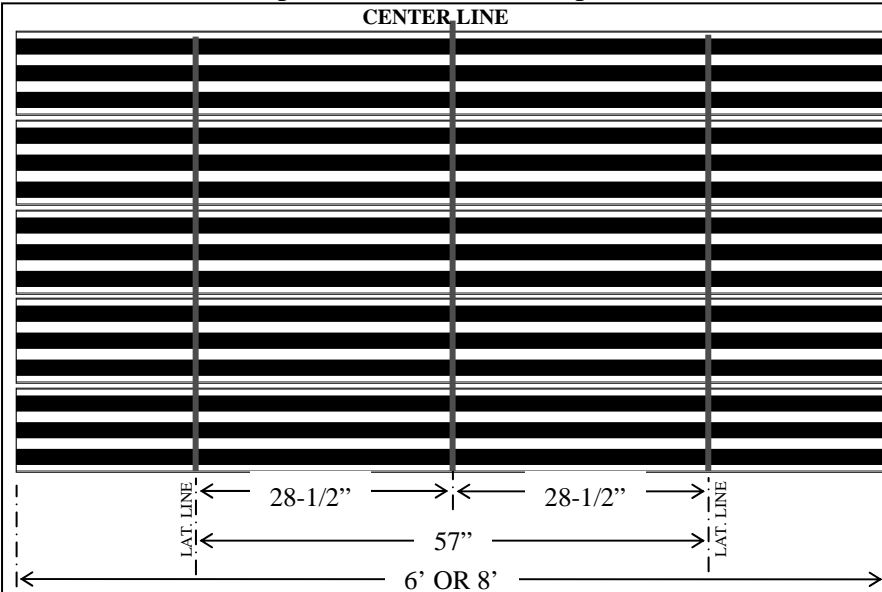

### DRAWING REFERENCE LINES:

Lay all 5 Planks side by side on a non-abrasive flat surface that will not damage the aluminum with the plank legs facing up as shown (bottom side up).

Draw a *Center Line* across all 5 Planks measuring equal distance from side edges. Then draw two *Lateral Lines* 28-1/2" parallel from *Center Line* on all boards (this will be your reference for bracket locations).

## IDENTIFY PLANK PARTS AND CLIP LOCATIONS

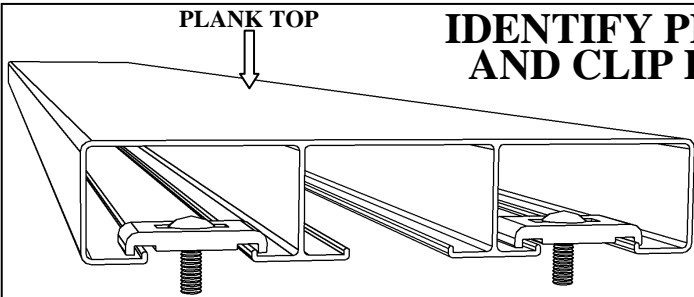

**CLIPS MOUNTED ON SIDE CHANNELS**  
These locations are for *Lateral Components*:  
When attaching Seat / Seat Brackets and Top "L" Brackets to Aluminum Planks.

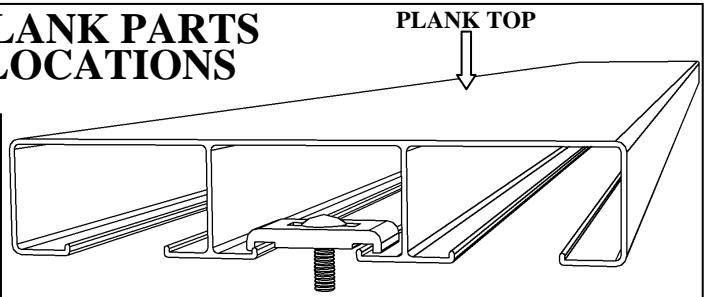

**CLIP MOUNTED ON CENTER CHANNEL**  
This location is for *Center Components*:  
When attaching Center Bracket, Center Channel and Center Spacer to Aluminum Planks.

700312

# 6' AND 8' ALUMINUM PARK CHIEF ASSEMBLY INSTRUCTIONS

**TOOLS REQUIRED:** 9/16" wrench, 1/2" wrench and powered screw driver or drill with Phillips tip No. 2.

- 1.- Lay 3 Planks aligned side by side on a non-abrasive flat surface that will not damage the aluminum with legs facing up.
- 2.- Place 2 Top "L" Brackets aligned with the flat edge along the reference *Lateral Lines*. Attach each Bracket with 6 clips and 1" carriage bolts mounted in Plank's side channels as shown. Hand fasten nuts. (see page 2 for clip locations).
- 3.- Insert 1-1/4" carriage bolt through clip and place in Plank's center channel aligned with the *Center Line*. While holding the clip/bolt, place Center Spacer, Center Channel and Center Bracket as shown. Hand fasten nut. (see page 2 for clip locations).
- 4.- Align parts assembled in step 4 to *Center Line* and attach Center Channel's outer holes to side planks using mounting clips and 1" bolts. Hand fasten nuts. (see page 2 for clip locations).
- 5.- Verify Center Spacer alignment. Then use clip and 1" carriage bolt mounted in center Plank's center channel to attach Center Spacer's side hole. (see page 2 for clip locations).
- 6.- Make sure Planks and Brackets are aligned. Then tighten all 16 nuts.
- 7.- Attach Table Top End Caps using 3/4" self-drilling screws.

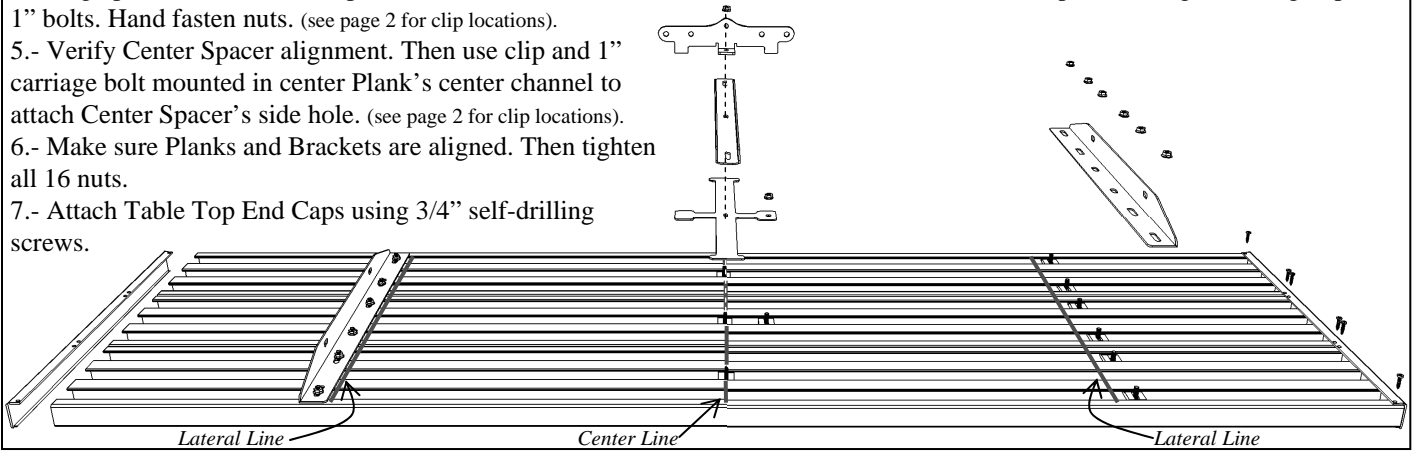

- 8.- Place brace between 2 table "J" Legs and insert 4-3/4" long bolt. Hand fasten nut.

**Note: Do not fully tighten any of the nuts from steps 8-10 until step 16 below.**

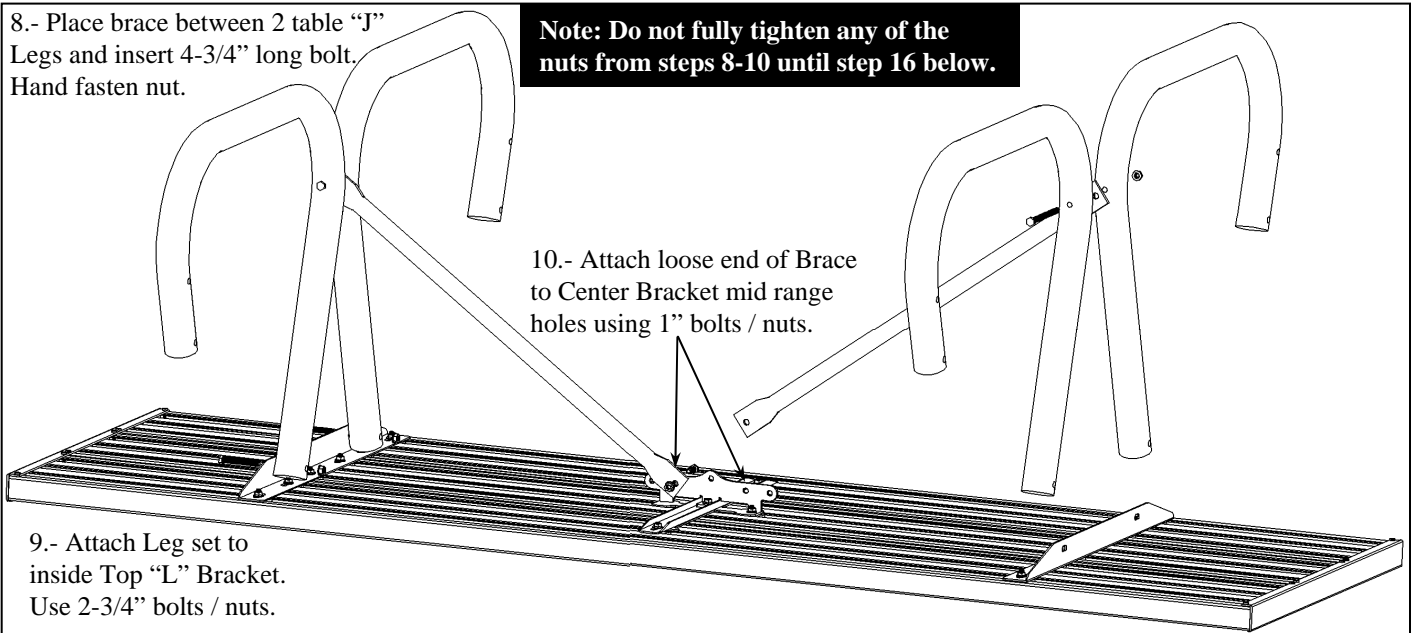

- 10.- Attach loose end of Brace to Center Bracket mid range holes using 1" bolts / nuts.

- 9.- Attach Leg set to inside Top "L" Bracket. Use 2-3/4" bolts / nuts.

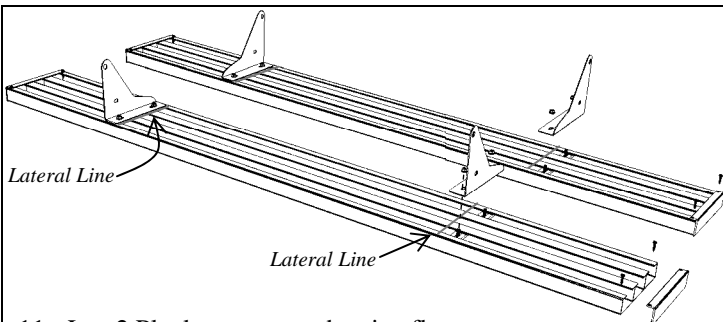

- 11.- Lay 2 Planks on a non-abrasive flat surface that will not damage the aluminum with legs facing up.
- 12.- Align Seat Bracket's flat edge to Plank's *Lateral Lines* as shown. Attach using clips and 1" carriage bolts mounted in side channels. Tighten firmly.
- 13.- Attach Seat End Caps using 3/4" self-drilling screws.

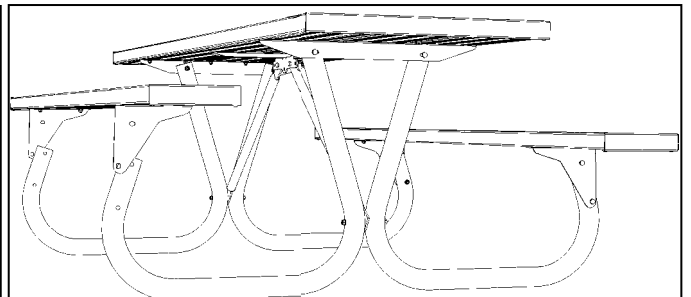

- 14.- Flip the partial table assembly into an upright position.
- 15.- Attach Seats to Frame with table legs inside Seat Brackets as shown. Use 2-3/4" bolts / nuts.
- 16.- Tighten all nuts firmly, including assembled parts in steps 8, 9 and 10.
- 17.- The Picnic Table is finished.