



Principal Plant and General Offices  
627 Amersale Drive  
Naperville, IL 60563

Toll Free: 1-800-323-5664  
Phone: 1-630-897-8489  
Fax: 1-630-897-0573  
Web Site: www.belson.com

# PARK CHIEF

Thank you for buying a BELSON OUTDOORS quality product.

**Please read and follow assembly instructions. Refer to appropriate page depending on the table you wish to put together. If the lumber is not provided by Belson, follow drilling instructions on page (2).**

## INDEX

- |  |  |
|--|--|
| 1) FRAME KIT CONTENTS                      | 4) WOOD TABLE U. ACCESS (ADA) ASSEMBLY INST. |
| 2) LUMBER CONTENTS AND WOOD DRILLING INST. | 5) RECYCLED PLASTIC TABLE ASSEMBLY INST.     |
| 3) WOOD TABLE 6' AND 8' ASSEMBLY INST.     | 6) RECYCLED PLASTIC TABLE (CONTINUED)        |

## **PC-WF-CO FRAME KIT CONTENTS:**

### **(2) SUPPORT BRACE**

700081

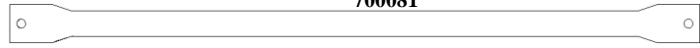

### **(1) HARDWARE BAG**

702302



### **(2) TOP "L" BRACKET**

700023

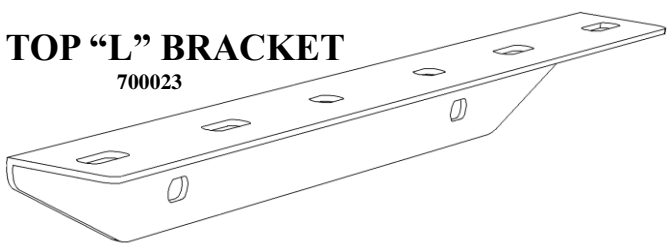

### **(2) SEAT BRACKET**

700004

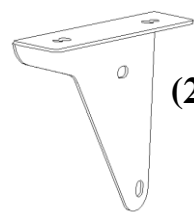

### **(2) SEAT BRACKET**

700005

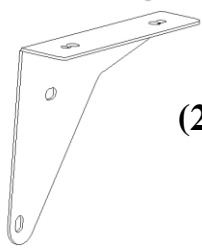

### **(1) CENTER CHANNEL**

700063

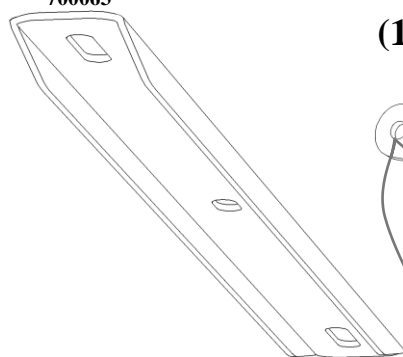

### **(1) CENTER BRACKET**

700043

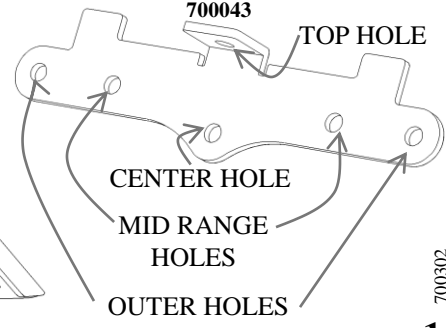

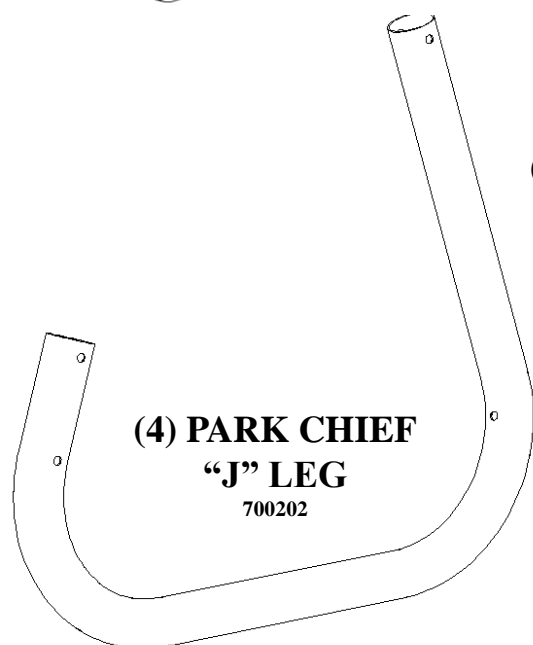

### **(4) PARK CHIEF "J" LEG**

700202

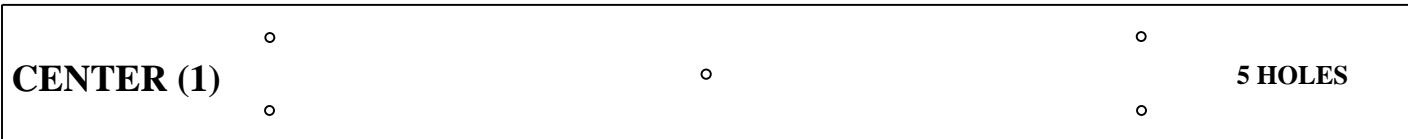
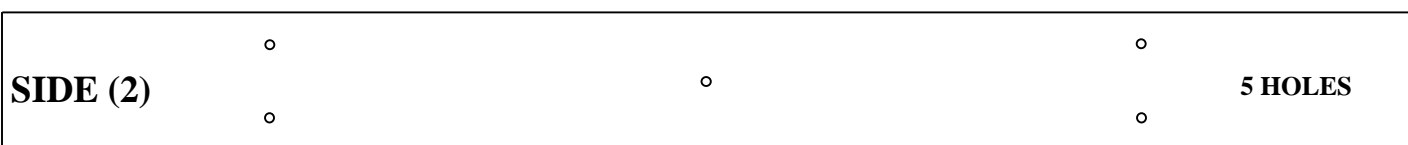

# BELSON PRE CUT & PRE DRILLED LUMBER KIT (OPTIONAL)

## LUMBER KIT CONTENTS:

	<b>CENTER (1)</b>	<b>5 HOLES</b>
	<b>SIDE (2)</b>	<b>5 HOLES</b>
	<b>SEAT (2)</b>	<b>4 HOLES</b>

THE SIZE OF THE BOARDS DEPENDS ON TABLE/KIT MODEL, EITHER 6' OR 8' SEE INSTRUCTIONS FOR ASSEMBLY.

## WOOD PICNIC TABLE DRILL PATTERN

**TOOLS NEEDED:** drill, 3/8" drill bit, pencil and tape measure or ruler.

**RECOMMENDED LUMBER:** 2" x 10" Nominal (1-1/2" thick by 9-1/4" wide).

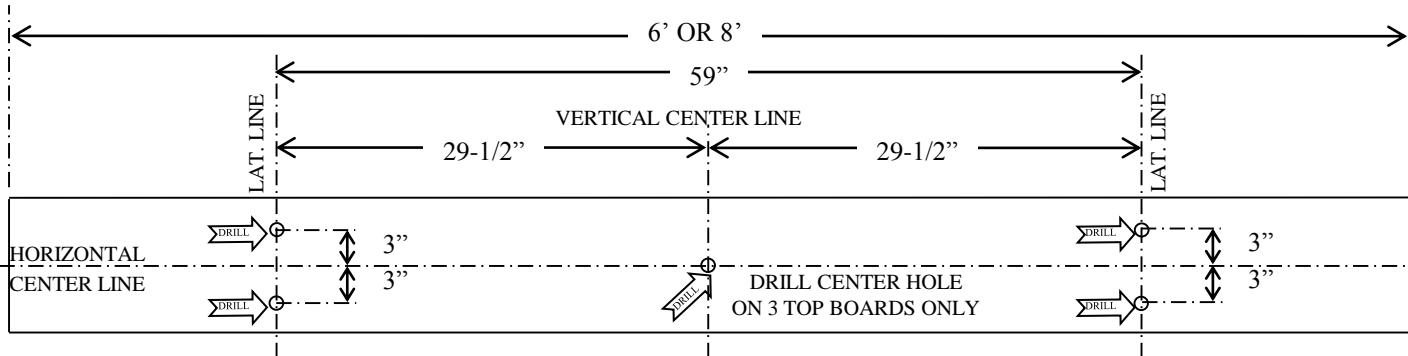

- 1.-Make sure all 5 boards are of consistent length, roughly 6' or 8' (two 6' and three 8' for ADA models).
- 2.-Lay all 5 boards on a flat surface that will not damage the wood with the best side down.
- 3.-Draw centered *Vertical* and *Horizontal Lines*, then two *Lateral Lines* 29-1/2" from *Vertical Center Line* on all boards (this will be your reference for hole locations).
- 4.-Drill 3/8" diameter holes in boards per drill pattern and notes indicated above.
- 5.-If desired, cut miters as per top of page lumber kit details and paint or seal before assembly.

# 6' AND 8' WOOD PARK CHIEF ASSEMBLY INSTRUCTIONS

**TOOLS REQUIRED:** 9/16" wrench and hammer.

- 1.- Insert carriage bolts through 3 Top Boards best face and lay (Side with 2 miters facing out - Center no miters - Side with 2 miters facing out ) on a non-abrasive flat surface that will not damage the lumber with the best side facing down.
- 2.- Align Top Boards and space them about 1/8" apart (use Seat Brackets as spacers).
- 3.- Place 2 Top "L" Brackets as shown and hand tighten nuts in place.
- 4.- Place the Center Channel with the legs up as shown and hand tighten the 2 outer nuts. Attach Center Bracket's center hole to the center bolt and hand tighten nut.

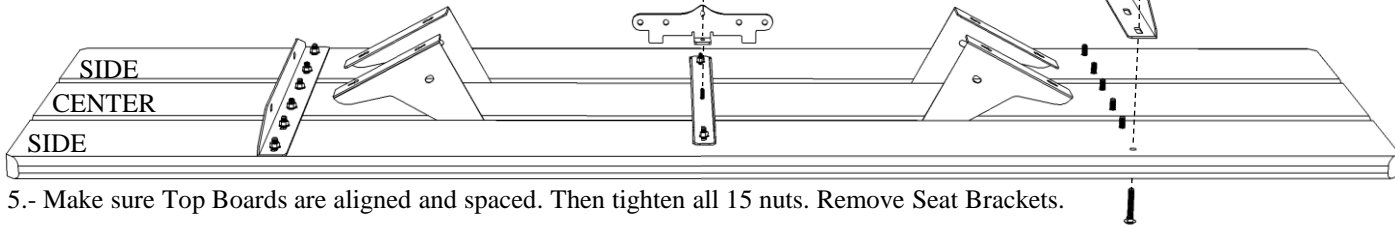

- 5.- Make sure Top Boards are aligned and spaced. Then tighten all 15 nuts. Remove Seat Brackets.

- 6.- Place brace between 2 table "J" Legs and insert 4-3/4" long bolt. Hand fasten nut.

**Note: Do not fully tighten any of the nuts from steps 6-8 until step 13 below.**

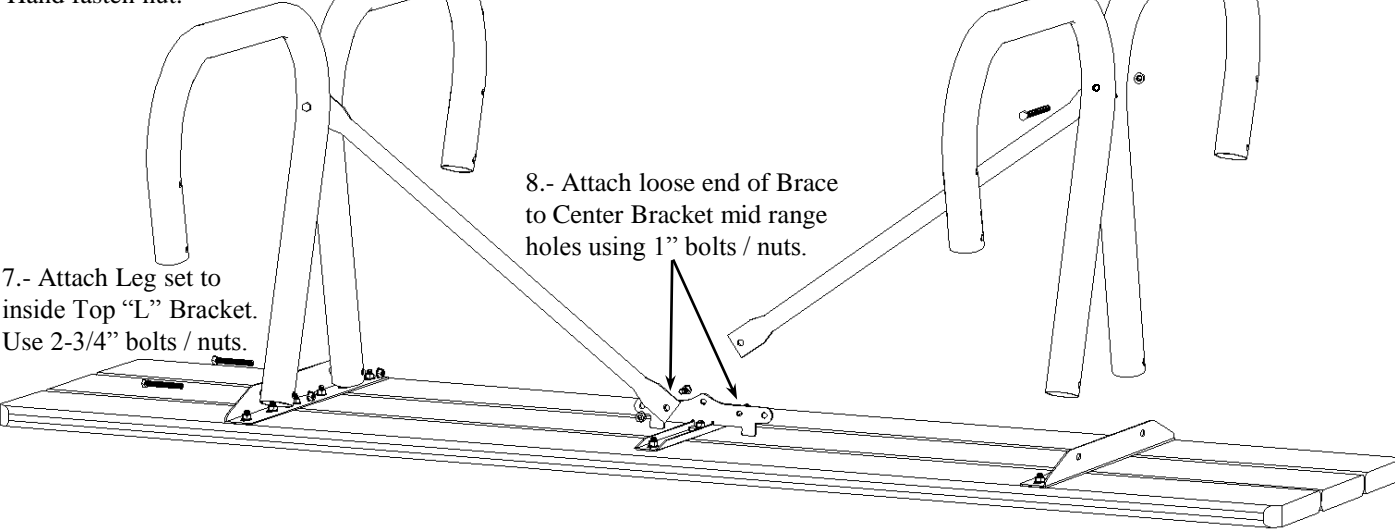

- 7.- Attach Leg set to inside Top "L" Bracket. Use 2-3/4" bolts / nuts.

- 8.- Attach loose end of Brace to Center Bracket mid range holes using 1" bolts / nuts.

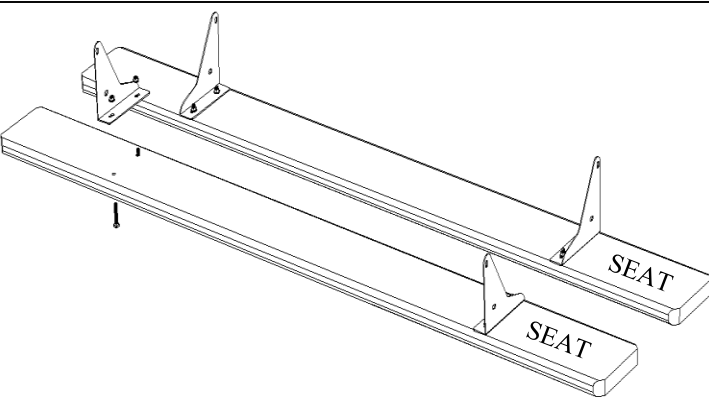

- 9.- Insert carriage bolts through Seat Boards best face and lay on a non-abrasive flat surface that will not damage the lumber with the best side facing down.
- 10.- Attach Seat Brackets to boards as shown and tighten firmly.

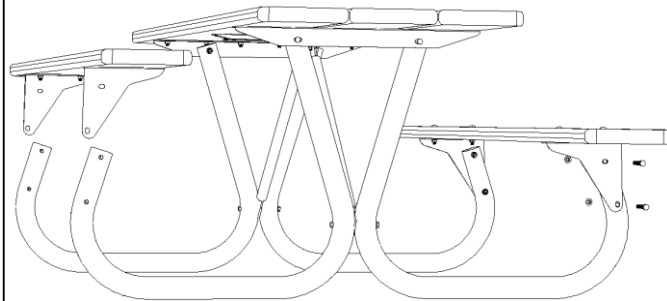

- 11.- Flip the partial table assembly into an upright position.
- 12.- Attach Seats to Frame with table legs inside Seat Brackets as shown. Use 2-3/4" bolts / nuts.
- 13.- Tighten all nuts firmly, including assembled parts in steps 6, 7 and 8.
- 14.- The Picnic Table is finished.