

Model # PLS6WB-P

Instructions Sheet

ECONO-MIZER BENCH

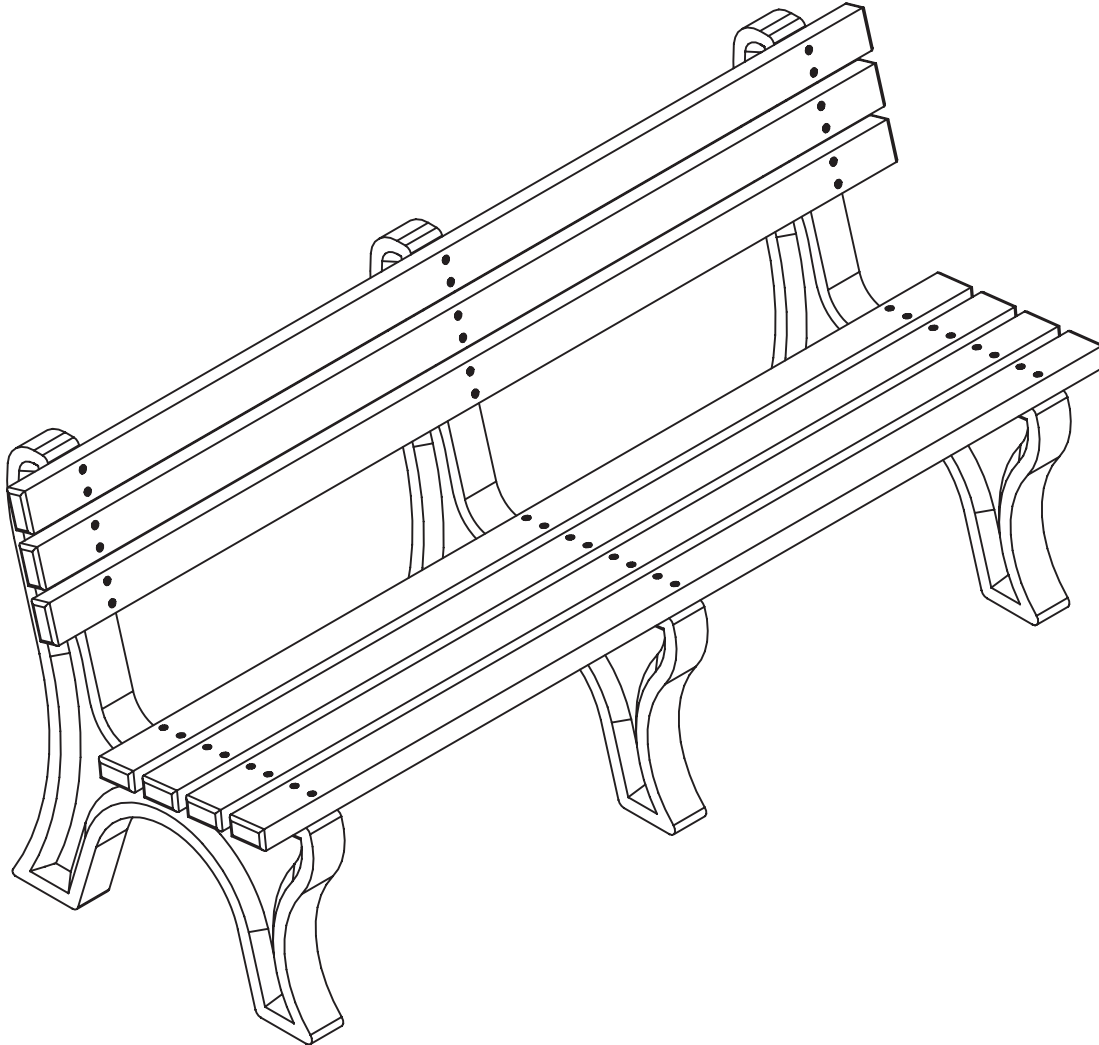

BEFORE ASSEMBLY, PLEASE MAKE SURE ALL COMPONENTS ARE INCLUDED.



FP - FASTENER PACK
(1) - ONE FASTENER PACK

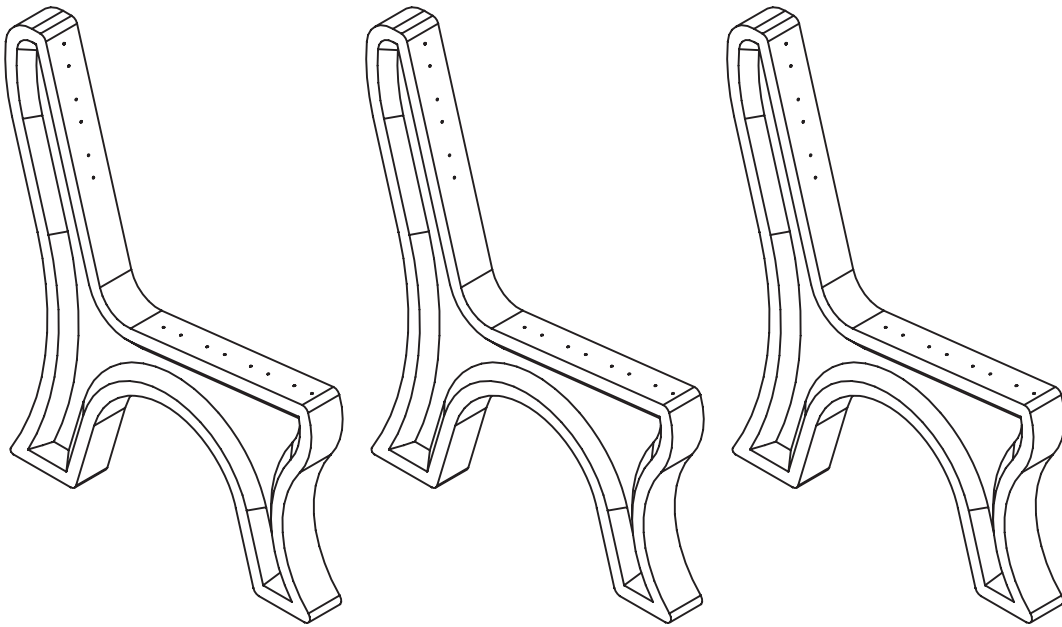

B - BENCH END
(3) - THREE BENCH ENDS

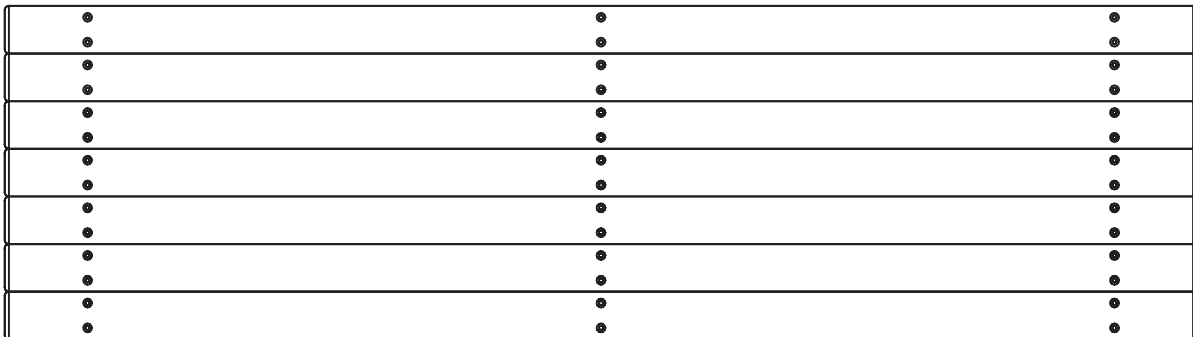

A - BENCH END
(7) - SEVEN BENCH BOARDS

BEFORE ASSEMBLY, PLEASE MAKE SURE ALL FASTENERS ARE INCLUDED.

42 - #12 X 3" FLAT HEAD PHILLIPS SCREW



ALSO NEEDED FOR THIS ASSEMBLY WILL BE THE FOLLOWING MATERIALS:

1 - #3 PHILLIPS DRIVE BIT

FIG #1:

IN ORDER TO MAKE THE ASSEMBLY OF THIS ECONO-MIZER BENCH EASIER WHILE GOING THROUGH THE ASSEMBLY PROCESS THE BOARD POSITIONS ARE NUMBERED AND WILL BE REFERENCED IN LATER STEPS.

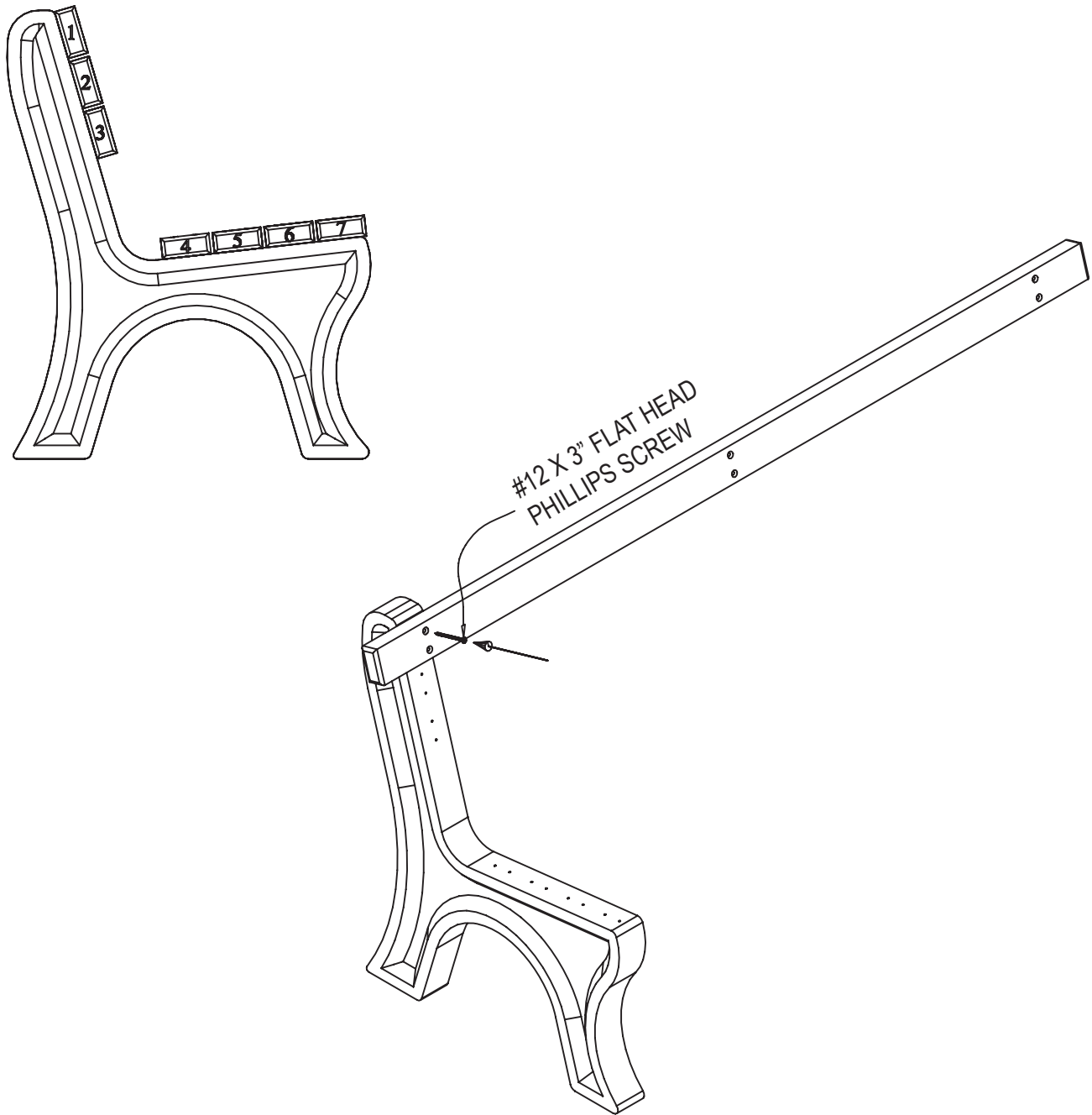

STEP #1:

STAND (1) ONE BENCH END UPRIGHT AND PLACE (1) ONE BENCH BOARD ON POSITIONS 1 BEING SURE TO ALIGN THE PRE-DRILLED HOLES TO THE PILOT HOLES IN THE BENCH END. AFTER THE HOLES ARE PROPERLY ALIGNED, FASTEN WITH (1) ONE #12 X 3" FLAT HEAD PHILLIPS SCREW IN THE TOP PRE-DRILLED HOLE.

NOTE: DO NOT TIGHTEN SCREW COMPLETELY. THIS WILL BE DONE IN A LATER STEP.

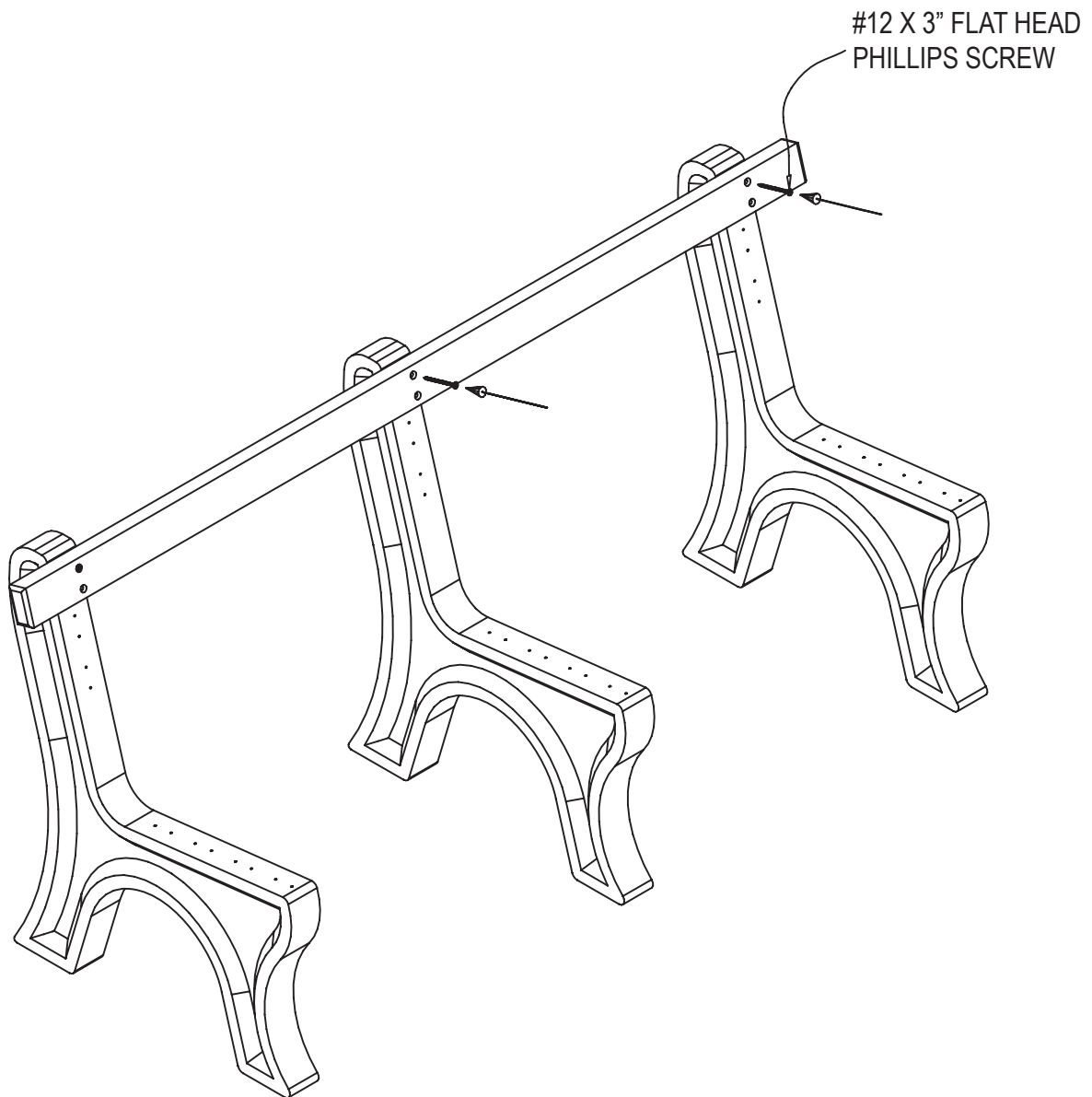

STEP #2:

STAND THE OTHER (2) TWO BENCH ENDS UPRIGHT, ONE AT A TIME, AND PLACE THE BENCH BOARD ALREADY ATTACHED TO THE FIRST BENCH END, ON POSITION 1 BEING SURE TO ALIGN THE PRE-DRILLED HOLES TO THE PILOT HOLES IN THE BENCH END. AFTER THE HOLES ARE PROPERLY ALIGNED, FASTEN WITH (1) ONE #12 X 3" FLAT HEAD PHILLIPS SCREW IN THE TOP PRE-DRILLED HOLE.

NOTE: DO NOT TIGHTEN SCREWS COMPLETELY. THIS WILL BE DONE IN A LATER STEP.

STEP 3:

ALIGN BOTTOM PRE-DRILLED HOLES TO THE PILOT HOLES IN THE BENCH END. AFTER HOLES ARE PROPERLY ALIGNED, FASTEN WITH (1) ONE #12 X 3" FLAT HEAD PHILLIPS SCREW PER HOLE.

NOTE: BE SURE TO TIGHTEN SCREWS COMPLETELY AFTER THIS STEP.

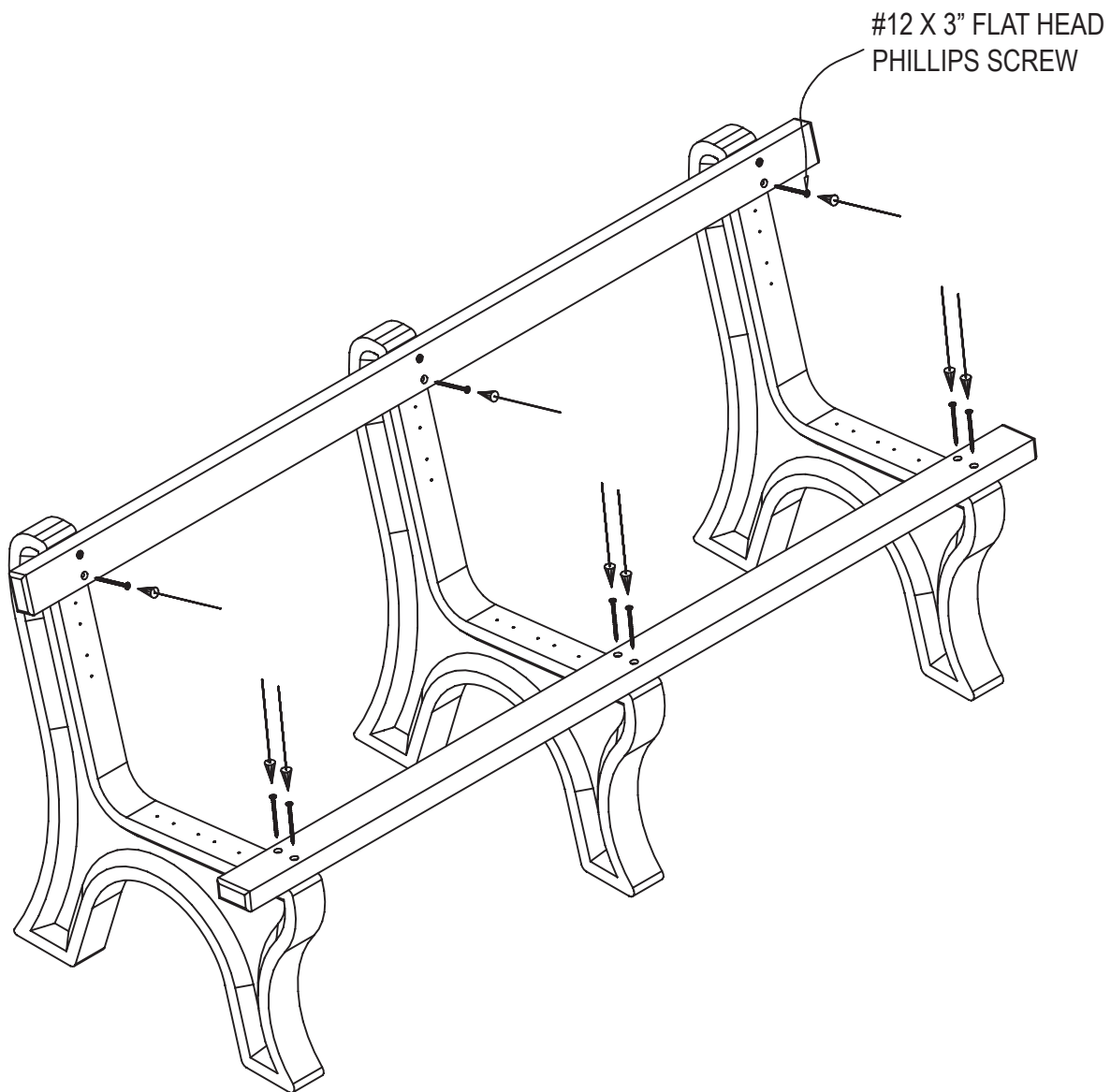

STEP 4:

PLACE A SECOND BENCH BOARD ON POSITION 7. REPEAT STEPS 1 - 3 TO ATTACH. USE (1) ONE #12 X 3" FLAT HEAD PHILLIPS SCREW PER HOLE TO FASTEN.

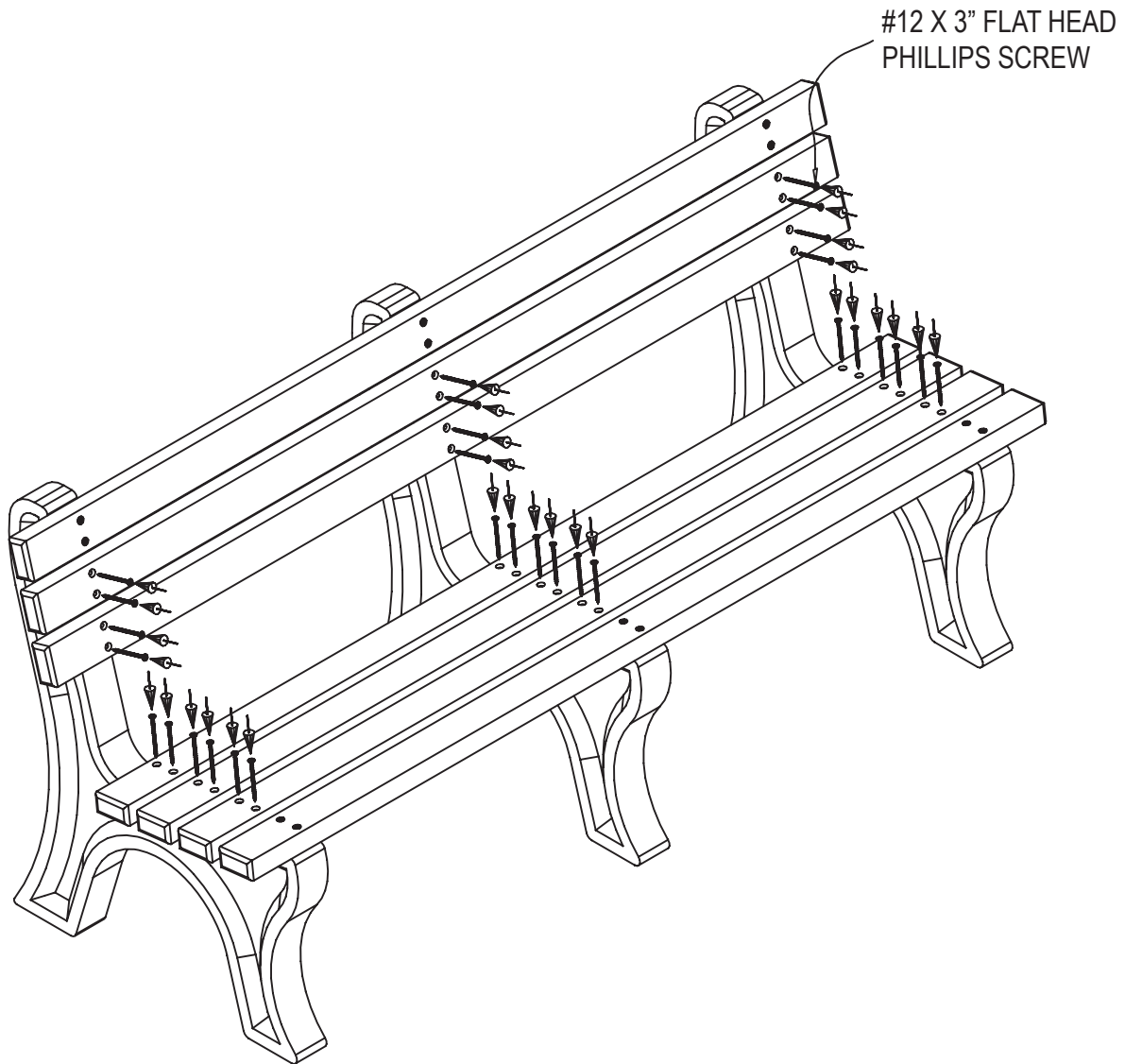

STEP 5:
REPEAT STEPS 1 - 3 TO ATTACH BENCH BOARDS ON POSITIONS 2, 3, 4, 5 & 6. USE (1) ONE #12 X 3"
FLAT HEAD PHILLIPS SCREW PER HOLE TO FASTEN.