

Model # PTEA6

Instructions Sheet

RECYCLED PLASTIC PICNIC TABLES W/ONE-PIECE MOLDED LEGS

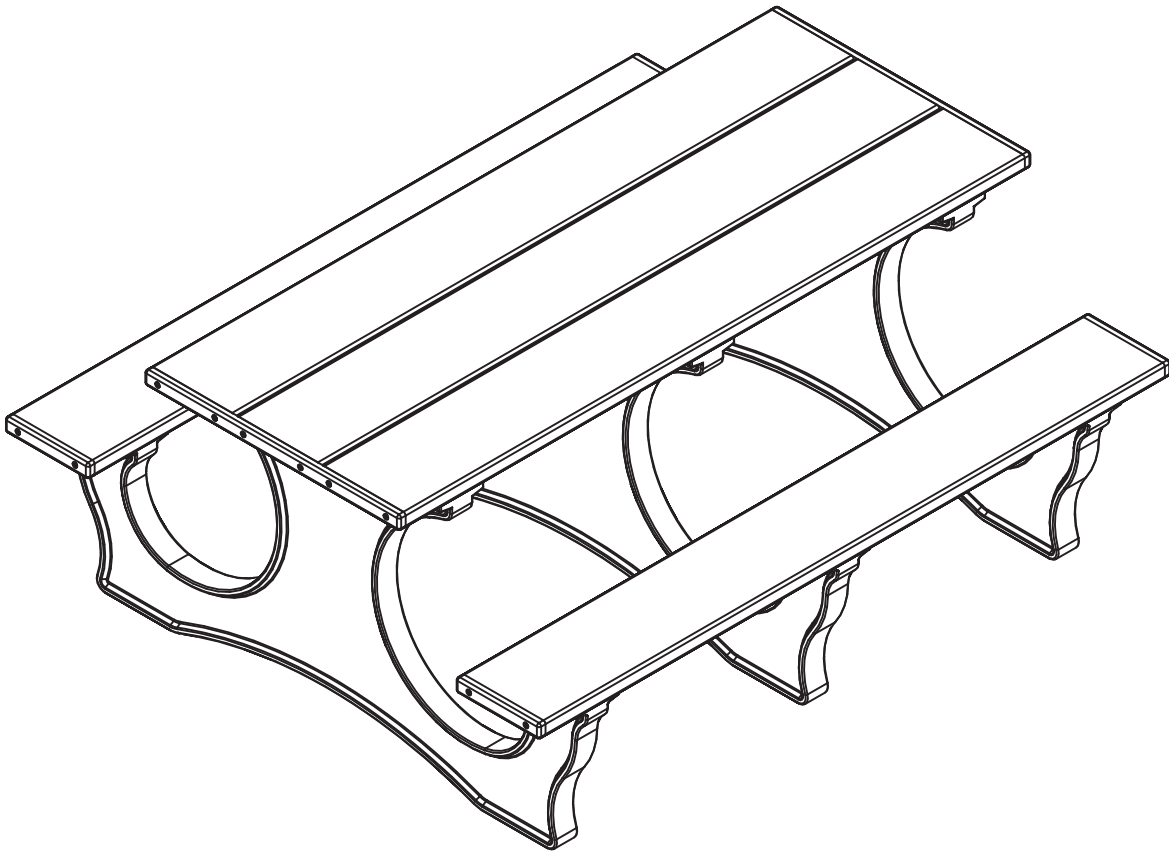

BEFORE ASSEMBLY, PLEASE MAKE SURE ALL COMPONENTS ARE INCLUDED.

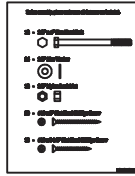

FP - FASTENER PACK
(1) - ONE FASTENER PACK

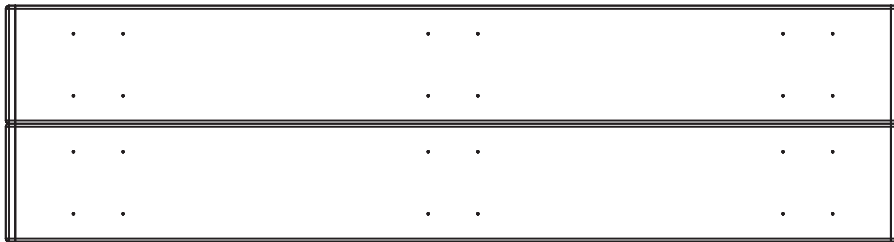

A - SEAT BOARD
(2) - TWO SEAT BOARDS

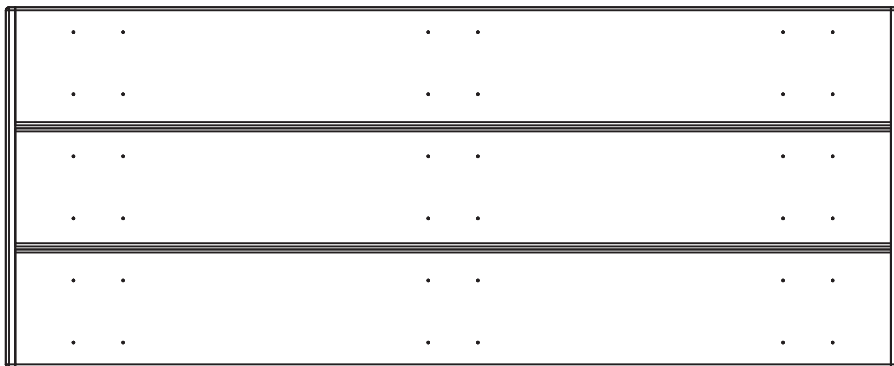

B - TABLE TOP
(1) - ONE TABLE TOP

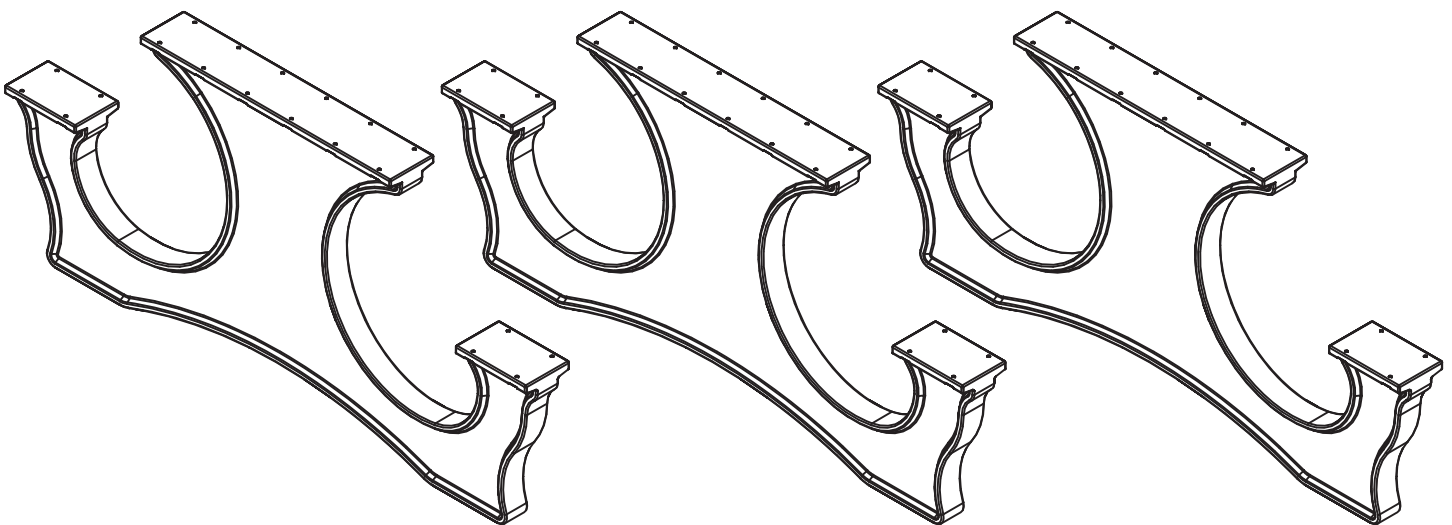

C - MOLDED TABLE LEG
(3) - THREE MOLDED TABLE LEGS

BEFORE ASSEMBLY, PLEASE MAKE SURE ALL FASTENERS ARE INCLUDED.

60 - 1/4" X 1-3/4" HEX HEAD LAG BOLT

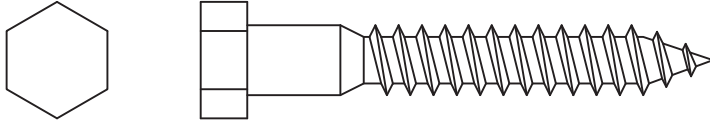

60 - 1/4" FLAT WASHER

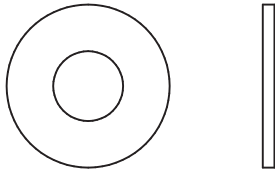

ALSO NEEDED FOR THIS ASSEMBLY WILL BE THE FOLLOWING MATERIALS:

1 - 7/16" SOCKET WRENCH OR 7/16" BOX END WRENCH

STEP #1:

PLACE THE TABLE TOP ASSEMBLY UPSIDE DOWN ONTO A PIECE OF CARDBOARD OR ANOTHER SOFT LEVEL SURFACE, TO PROTECT IT DURING INSTALLATION. PLACE ONE MOLDED LEG ON THE TABLE TOP AS SHOWN BELOW. ALIGN THE PRE-DRILLED HOLES IN THE MOLDED LEG WITH THE PILOT HOLES IN THE TABLE TOP. USE (1) ONE 1/4" X 103/4" LAG BOLT AND (1) ONE 1/4" FLAT WASHER PER HOLE, TO SECURE.

NOTE: DO NOT TIGHTEN BOLTS COMPLETELY. THIS WILL BE DONE IN A LATER STEP.

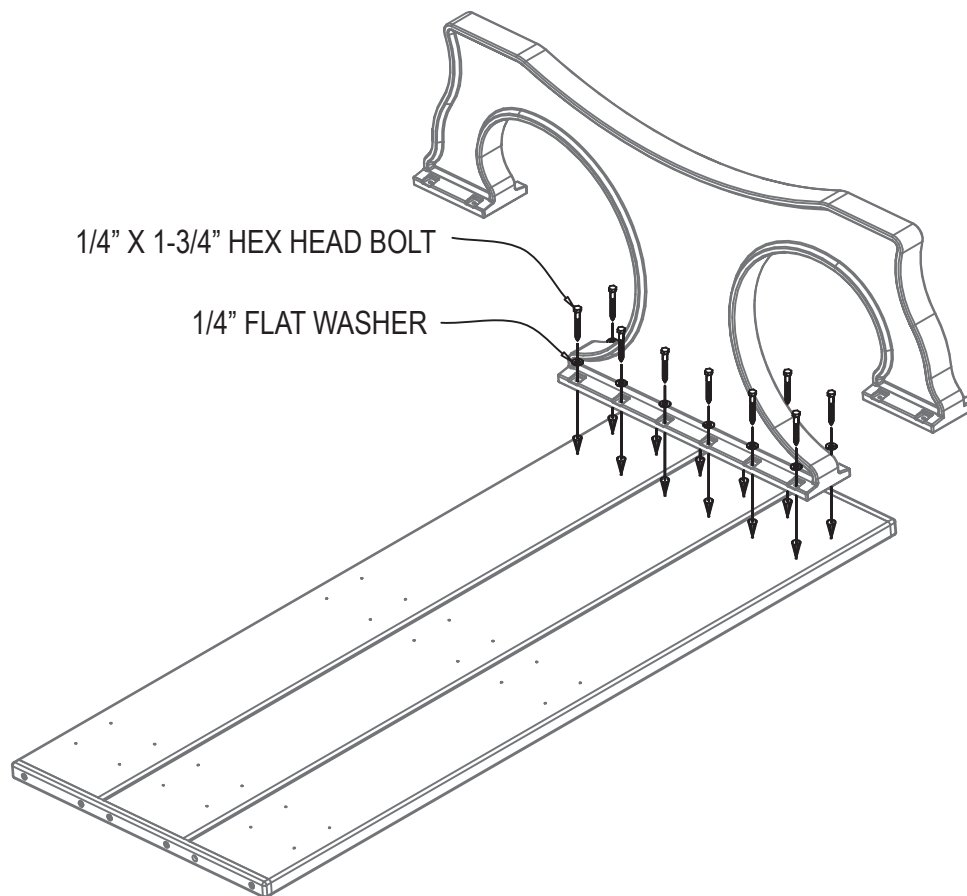

STEP #2:

PLACE THE REMAINING MOLDED TABLE LEGS IN POSITION, AS SHOWN BELOW, BEING SURE TO ALIGN THE PRE-DRILLED HOLES TO THE PILOT HOLES IN THE TABLE TOP. AFTER THE HOLES ARE PROPERLY ALIGNED, FASTEN WITH (1) ONE 1/4" X 1-3/4" LAG BOLT AND (1) ONE 1/4" FLAT WASHER PER HOLE TO SECURE.

NOTE: DO NOT TIGHTEN BOLTS COMPLETELY. THIS WILL BE DONE AT A LATER STEP.

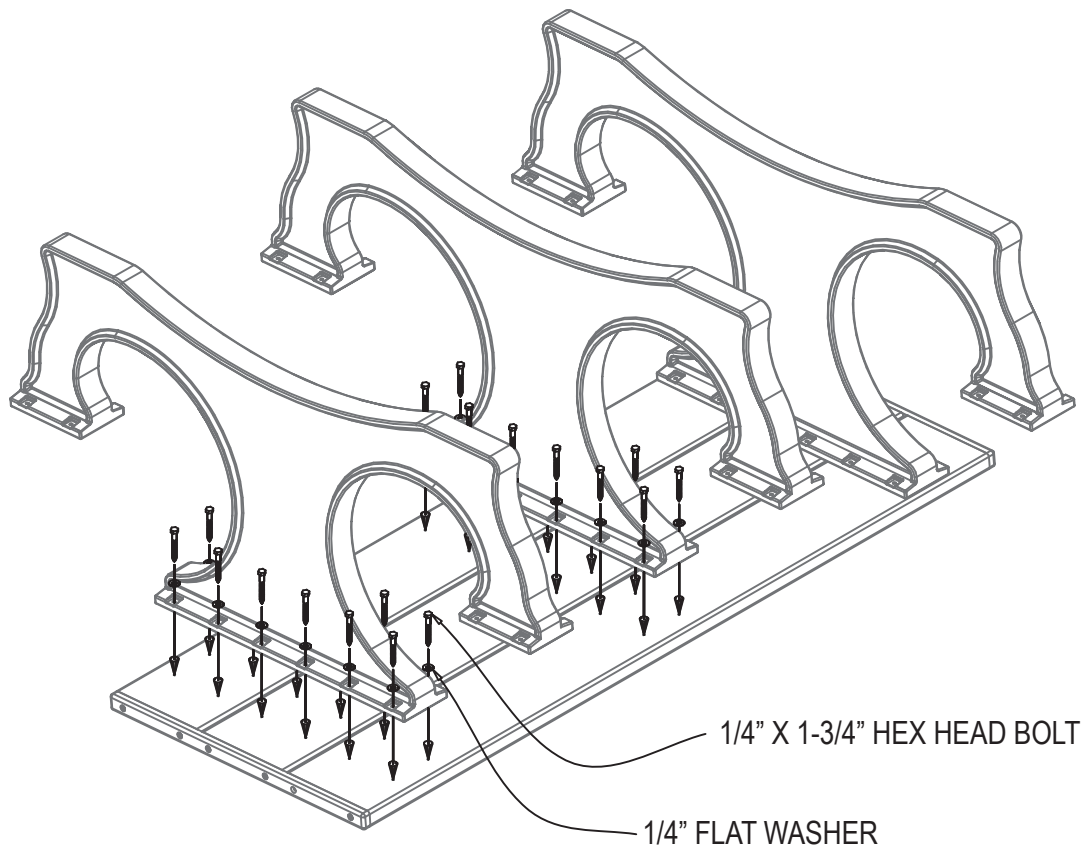

STEP #3:

PLACE THE SEAT BOARDS IN POSITION, AS SHOWN BELOW, BEING SURE TO ALIGN THE PILOT HOLES TO THE PRE-DRILLED HOLES IN THE MOLDED TABLE LEGS. AFTER THE HOLES ARE PROPERLY ALIGNED, FASTEN WITH (1) ONE 1/4" X 1-3/4" LAG BOLT AND (1) ONE 1/4" FLAT WASHER PER HOLE TO SECURE.

NOTE: BE SURE TO TIGHTEN ALL FASTENERS AFTER COMPLETING THIS STEP.

PLEASE USE CAUTION NOT TO OVER-TIGHTEN THE FASTENERS.

