

Model # RS8WB-P

Instructions Sheet

ELITE OUTDOOR PARK BENCH 8'

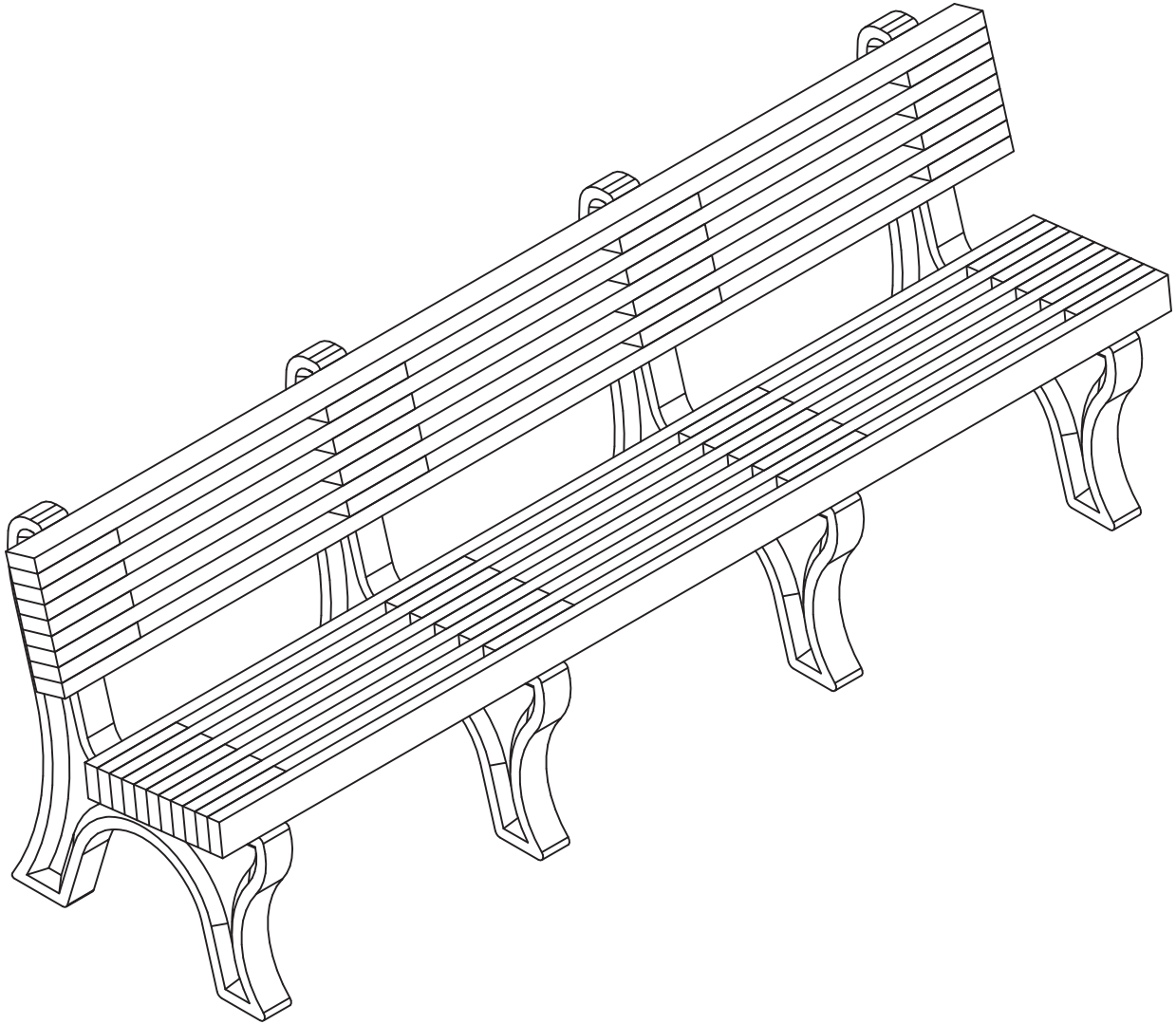

BEFORE ASSEMBLY, PLEASE MAKE SURE ALL COMPONENTS ARE INCLUDED.



FP - FASTENER PACK
(1) - ONE FASTENER PACK

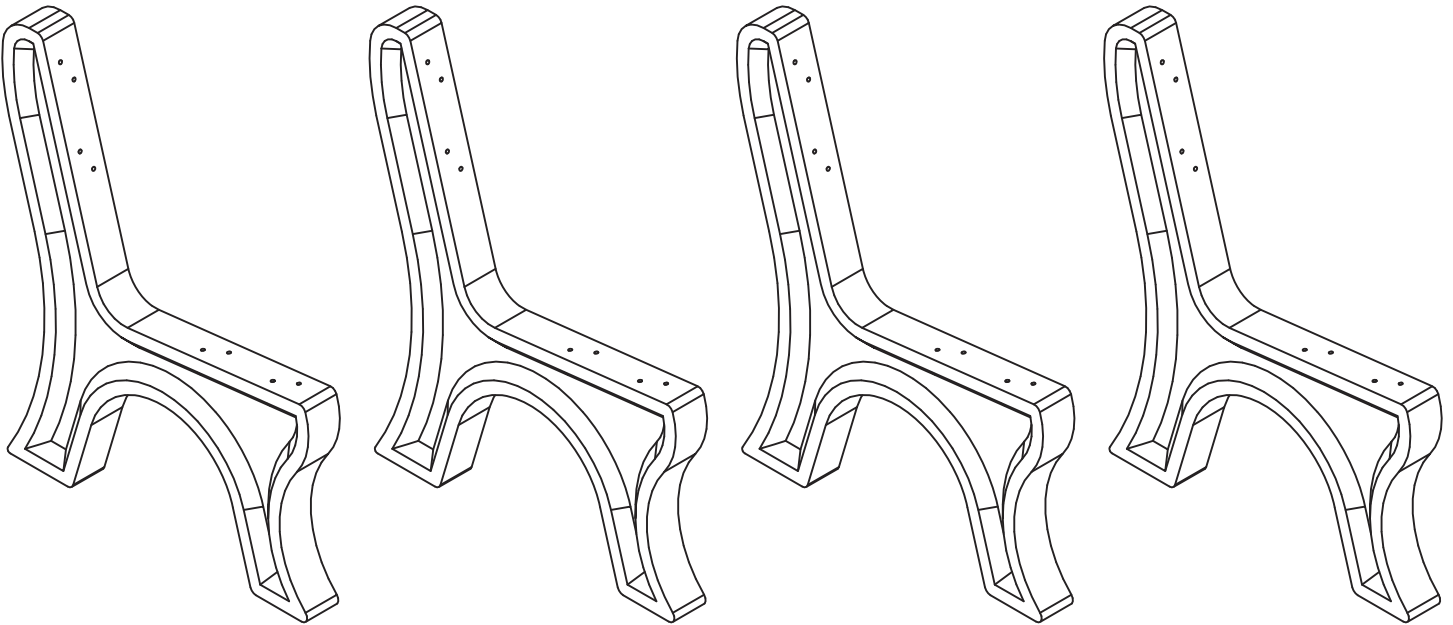

(4) - FOUR BENCH ENDS

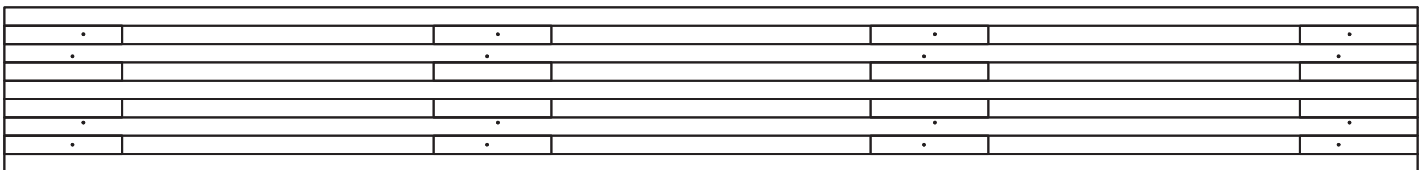

(1) - ONE BACK BENCH BOARD

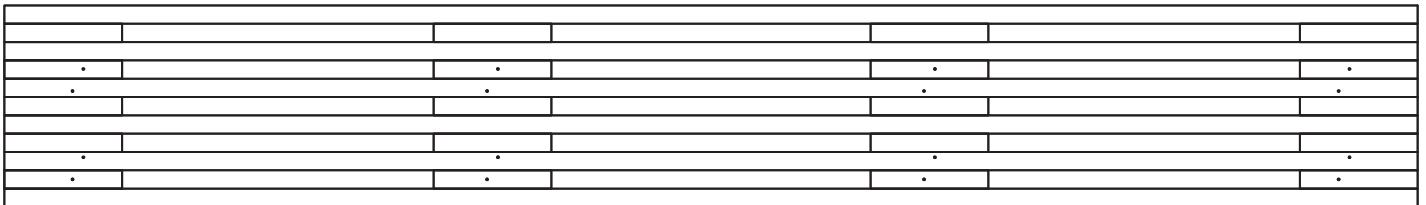

(1) - ONE SEAT BENCH BOARD

BEFORE ASSEMBLY, PLEASE MAKE SURE ALL FASTENERS ARE INCLUDED.

32 - #12 X 3" FLAT HEAD PHILLIPS SCREWS



ALSO NEEDED FOR THIS ASSEMBLY WILL BE THE FOLLOWING MATERIALS:

1 - 3" PHILLIPS DRIVE BIT

STEP #1:

ON THE CARDBOARD THAT THE BENCH WAS SHIPPED IN, STAND THE SEAT BENCH BOARD ON EDGE WITH THE PILOT HOLES CLOSER TO THE GROUND, ON A LEVEL SURFACE.

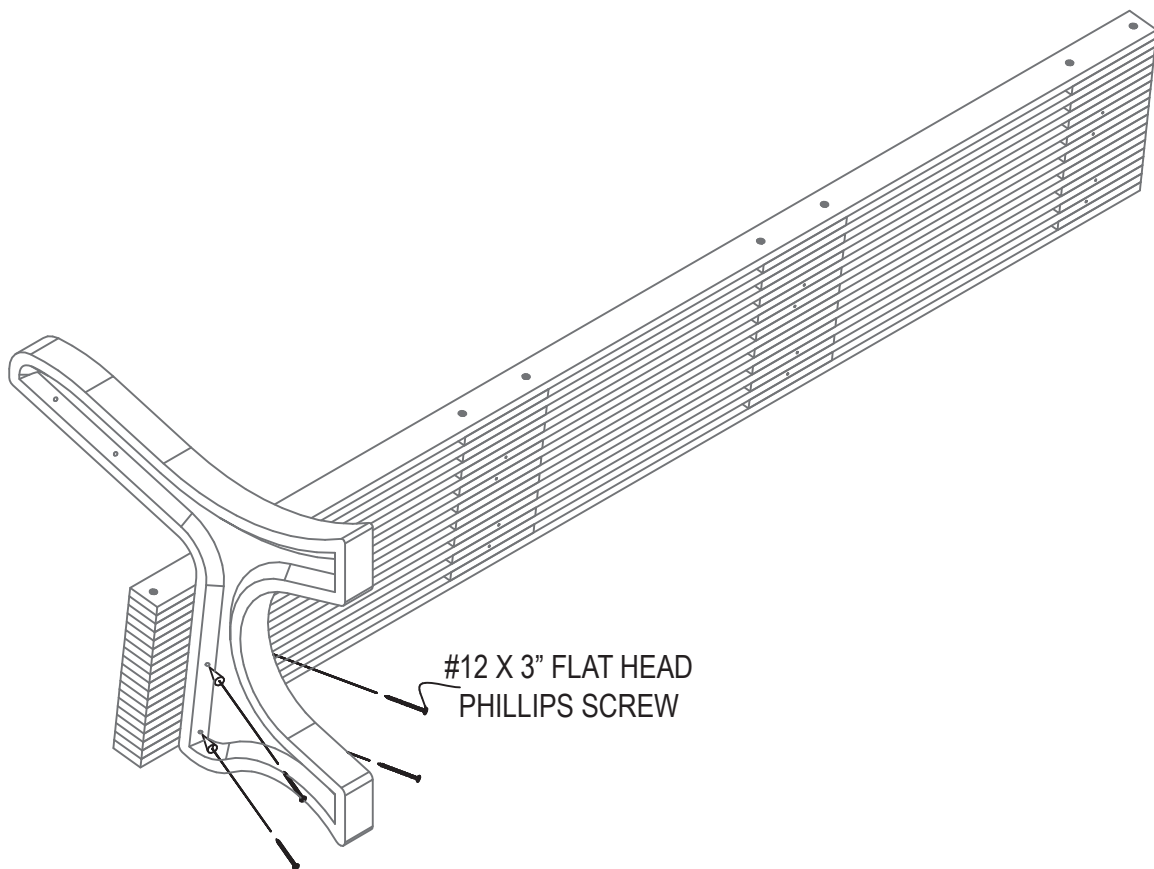

STEP #2:

PLACE IN POSITION (1) ONE BENCH END AS SHOWN IN DIAGRAM, BEING SURE TO ALIGN THE PILOT HOLES TO THE PRE-DRILLED HOLES IN THE BENCH END. AFTER THE HOLES ARE PROPERLY ALIGNED, FASTEN WITH (1) ONE #12 X 3\" FLAT HEAD PHILLIPS SCREW PER HOLE.

NOTE: DO NOT TIGHTEN SCREW COMPLETELY. THIS WILL BE DONE IN A LATER STEP.

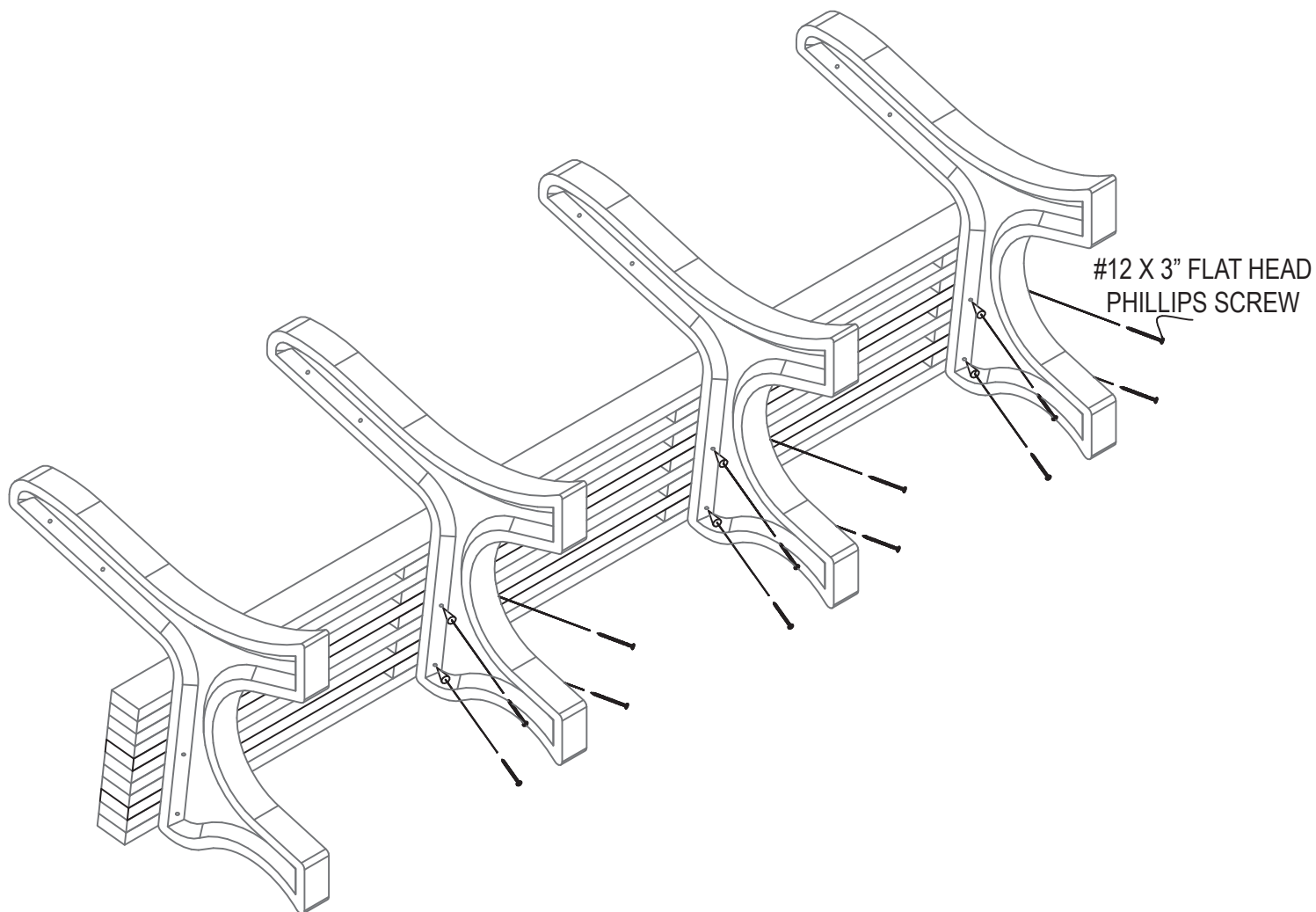

STEP #3:
REPEAT STEP #2 FOR THE REMAINING BENCH ENDS.

NOTE: BE SURE TO TIGHTEN ALL SCREWS COMPLETELY AFTER THIS STEP.

STEP #4:

PLACE THE BENCH IN THE UP RIGHT POSITION. USE CARE, FOR THE BENCH WEIGHS APPROXIMATELY 150 POUNDS.

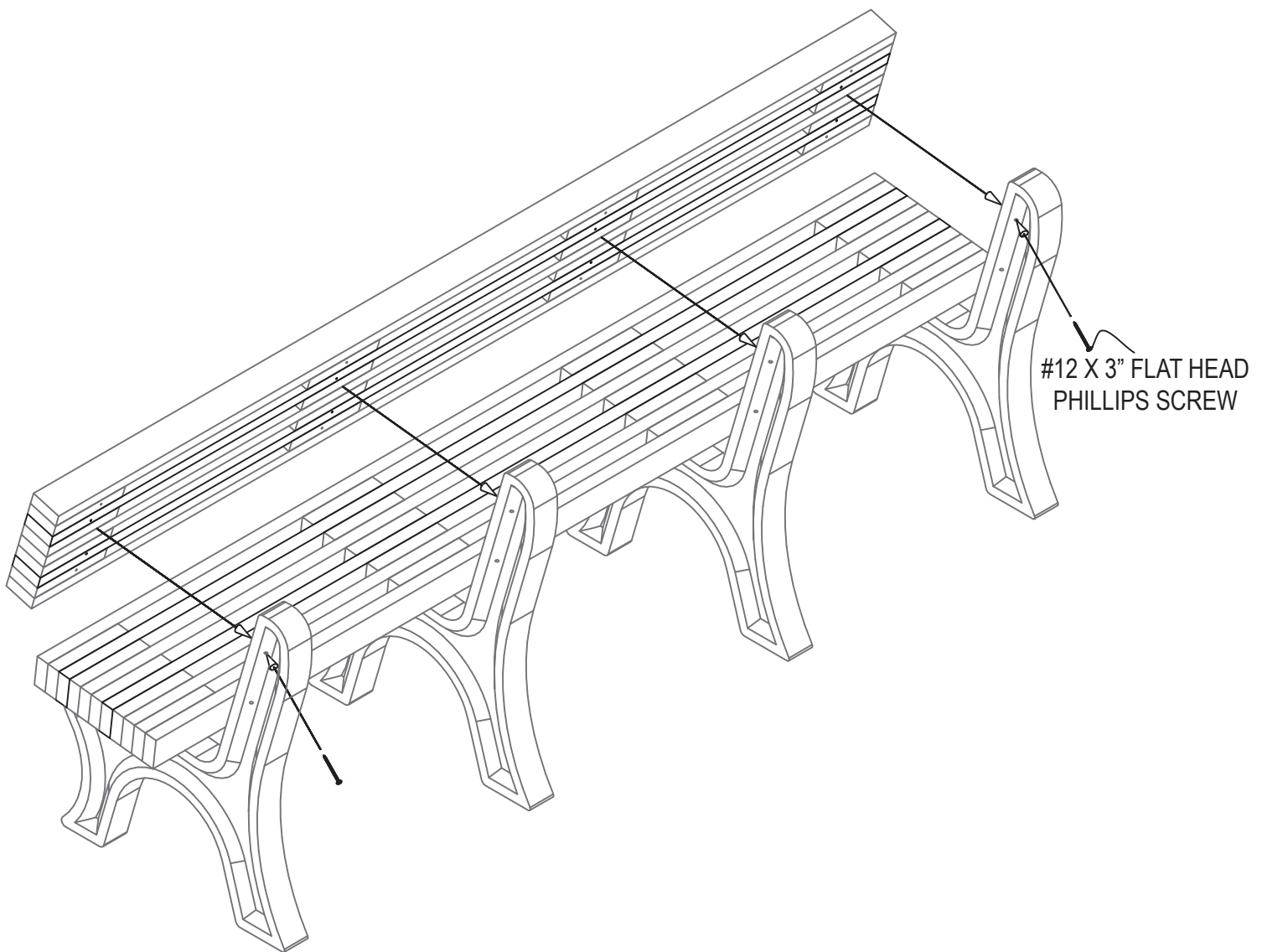

STEP #5:

PLACE THE BACK BENCH BOARD IN POSITION SHOWN IN DIAGRAM. USE (1) ONE #12 X 3" FLAT HEAD PHILLIPS SCREW IN THE TOP HOLE OF THE LEFT BENCH END. REPEAT FOR THE RIGHT BENCH END.

NOTE: DO NOT TIGHTEN SCREWS COMPLETELY. THIS WILL BE DONE IN A LATER STEP.

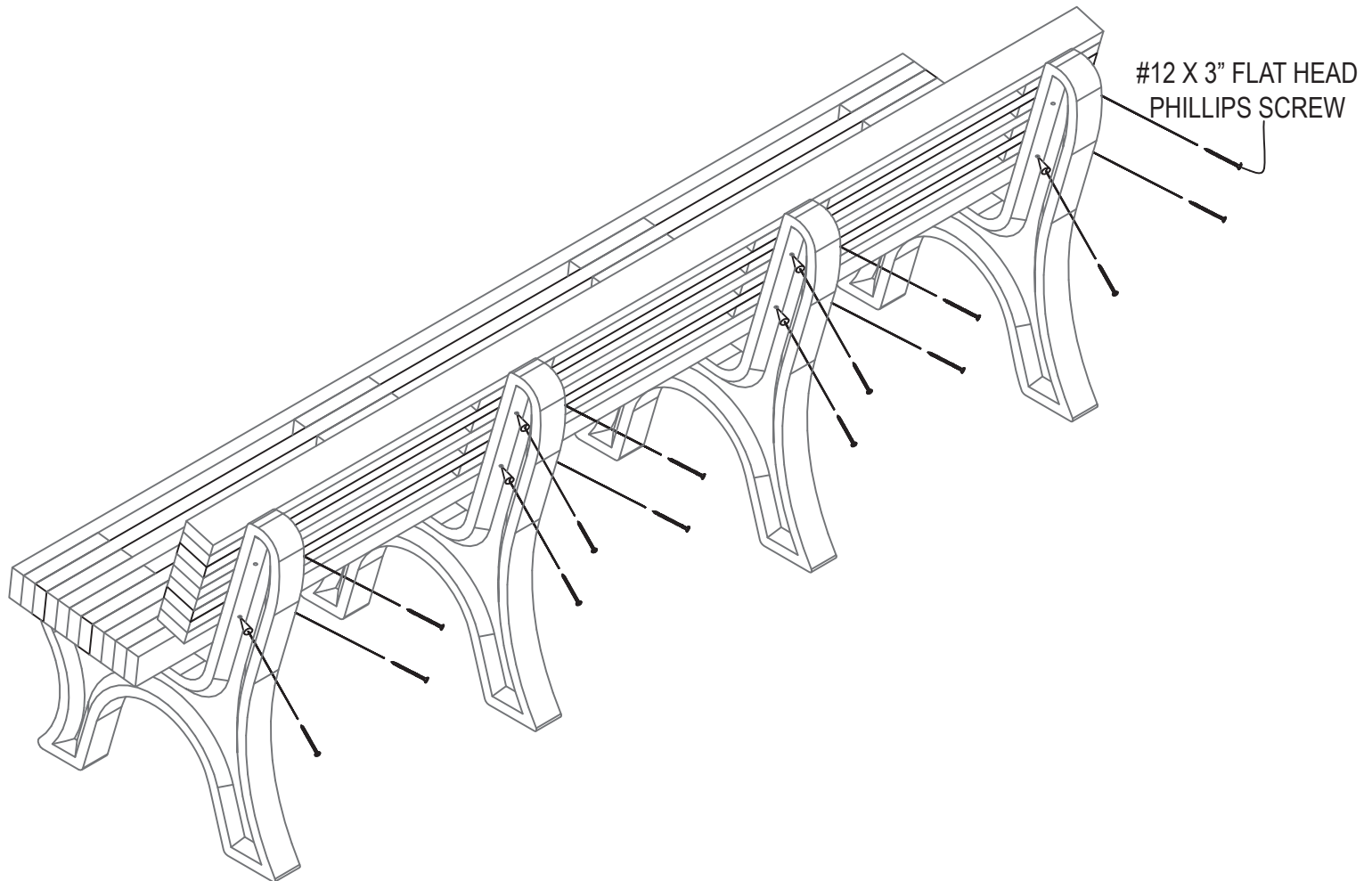

STEP #6:

USING (1) ONE #12 X 3" FLAT HEAD PHILLIPS SCREW PER HOLE, FINISH FASTENING THE BACK BENCH BOARD TO THE BENCH ENDS.

NOTE: BE SURE TO TIGHTEN ALL SCREWS COMPLETELY AFTER THIS STEP.